

40G QSFP+ LR4 and ER4 Transceiver Datasheet



Features:

- 4 independent full-duplex channels up to 11.2Gbps data rate per wavelength
- Distance up to 40km
- Single 3.3V Power supply
- Utilizes two standard LC optical connector
- QSFP+ Hot Pluggable
- Compliant with the QSFP+ MSA SFF-8436 Specification
- Compliant with IEEE802.3ba
- I2C interface with integrated Digital Diagnostic Monitoring
- Operating Case Temperature Standard: 0°C ~+70°C

Applications:

- 40GBASE-LR4/ER4 40G Ethernet links
- Infiniband 4X SDR DDR QDR
- 40G Telecom connections

Product Description

Trixon 40G 10km QSFP+ LR4 and ER4 Transceiver products is a 4x10G hot pluggable optical transceiver. The optical connectivity is based on two SMF LC connectors, one for Tx and one for Rx. The Tx and Rx each consist of 4 10GB/s CWDM channels, whose wavelengths are in the 1300nm range. The QSFP+-LR4 and ER4 transceiver is designed for applications based on the IEEE802.3ba 40GBASE-LR4 standard of up to 10km, 40GBASE-ER4 standard of up to 40km reach.

Ordering information

Part No.	Data Rate	Laser	Fiber Type	Distance* ^{Note1}	Optical Interface	Latch Color	Temp. * ^{Note2}	DDMI
TQS-FG10-31DCR	40Gbps	1271nm DFB	SMF	10km	LC	Blue	ST	Y
		1291nm DFB						
		1311nm DFB						
		1331nm DFB						
TQS-FG10-30DCR	45Gbps	1271nm DFB	SMF	10km	LC	Blue	ST	Y
		1291nm DFB						
		1311nm DFB						
		1331nm DFB						
TQS-FG40-31DCR	41.25Gbps	1271nm DFB	SMF	40km	LC	Red	ST	Y
		1291nm DFB						
		1311nm DFB						
		1331nm DFB						

Note1: with 9/125µm SMF

Note2: ST: -5 ~ +70 deg C

Regulatory Compliance

Feature	Standard	Performance
Electrostatic Discharge (ESD) to the Electrical Pins	MIL-STD-883G Method 3015.7	HBM class 1, 1000volts and above, Contact discharge on Golden Finger.
Electrostatic Discharge to the enclosure	EN 55024:1998+A1+A2 IEC-61000-4-2 GR-1089-CORE	Compliant with standards.
Electromagnetic Interference (EMI)	FCC Part 15 Class B EN55022:2006 CISPR 22B :2006 VCCI Class B	Compliant with standards Noise frequency range: 30MHz to 18 GHz. System margins depend on customer host board and chassis design.
Immunity	IEC 61000-4-3 EN 55024:1998+A1+A2	Compliant with standards.
Laser Eye Safety	FDA 21CFR 1040.10 and 1040.11 EN (IEC) 60825-1:2007 EN (IEC) 60825-2:2004+A1	CDRH compliant and Class I laser product.
Component Recognition	UL and CUL EN60950-1:2006	Compliant with standards.
RoHS6	2002/95/EC 4.1&4.2 2005/747/EC 5&7&13	Compliant with standards* ^{note3}

Note3:

In light of item 5 in RoHS exemption list of RoHS Directive 2002/95/EC, Item 5: Lead in glass of cathode ray tubes, electronic components and fluorescent tubes.

In light of item 13 in RoHS exemption list of RoHS Directive 2005/747/EC, Item 13: Lead and cadmium in optical and filter glass. The three exemptions are being concerned for Trixon transceivers, because Trixon transceivers use glass, which may contain Pb, for components such as lenses, windows, isolators, and other electronic components.

Absolute Maximum Ratings*_{Note4}

Parameter	Symbol	Min	Max	Unit
Storage Temperature	T_S	-40	+85	°C
Supply Voltage	V_{CC}	0	+3.6	V
Operating Humidity		0	85	%

Note4: Exceeding any one of these values may destroy the device permanently.

Recommended Operating Conditions

Parameter	Symbol	Min	Typical	Max	Unit	Notes
Operating Case Temperature	T_C	-5	-	70	°C	ST
Power Supply Voltage	VCC	3.135	3.3	3.465	V	
Power Supply Current	I_{CC}	-	-	1100	mA	ST
I2C Clock Frequency	f_{cl}	-	-	100	kHz	

Performance Specifications – Electrical

Parameter	Symbol	Min	Typ.	Max	Unit	Notes
Transmitter						
TX CML Inputs Voltage (Differential)	V_{in}	190	-	700	mVpp	AC coupled inputs
Input Impedance (Differential)	Z_{in}		100		ohm	
LP_MODE Input Voltage – High		2.0	-	$V_{CC}+0.3$	V	
LP-MODE Input Voltage – Low		-0.3	-	0.8	V	
INTL Output Voltage – High		2.4	-	$V_{CC}+0.3$	V	OC output, should be pull up with 4.7K – 10 K Ω on the host board
INTL Output Voltage – Low		-	-	0.8	V	$I_{OL} = 1mA$
Receiver						
CML Outputs Voltage (Differential)	V_{out}	300	-	850	mVpp	AC coupled outputs
Output Impedance (Differential)	Z_{out}	-	100	-	ohm	
Output Transition Time		28			ps	20%~80%

Performance Specifications – Optical

40G Ethernet

Parameter	Symbol	Min	Typ.	Max	Unit
Transmitter					
Centre Wavelength	λ_c	1264.5	1271	1277.5	nm
		1284.5	1291	1297.5	

		1304.5	1311	1317.5	
		1324.5	1331	1337.5	
Spectral Width (-20dB)	$\Delta\lambda$	-	-	1	nm
Transmitter Signal Rate			10.3125		Gbps
SMSR		30			dB
TDP, each Lane	TDP			2.6	dB
Optical Return Loss Tolerance	TOL			20	dB
Average Output Power	P _{out}	-7	-	2.3	dBm
Extinction Ratio	ER	3.5	-	-	dB
Output Optical Eye		Compliant With IEEE Std 802.3ba-2010			

Parameter	Symbol	Min	Typ.	Max	Unit
Receiver					
Centre Wavelength	λ_c	1264.5	1271	1277.5	nm
		1284.5	1291	1297.5	
		1304.5	1311	1317.5	
		1324.5	1331	1337.5	
Receiver Sensitivity* ^{note5}	SEN	-	-	-11.5	dBm
Receiver Overload	P _{max}	2.3	-	-	dBm
LOS De-Assert	LOS _D	-	-	-11.5	dBm
LOS Assert	LOS _A	-20	-	-	dBm
LOS Hysteresis	LOS _H	0.5	-	5	dB

45G SDH

Parameter	Symbol	Min	Typ.	Max	Unit
Transmitter					
Centre Wavelength	λ_c	1264.5	1271	1277.5	nm
		1284.5	1291	1297.5	
		1304.5	1311	1317.5	
		1324.5	1331	1337.5	
Spectral Width (-20dB)	$\Delta\lambda$	-	-	1	nm
Transmitter Signal Rate			11.2		Gbps
SMSR		30			dB
TDP, each Lane	TDP			2.6	dB
Optical Return Loss Tolerance	TOL			20	dB
Average Output Power	P _{out}	-7	-	2.3	dBm
Extinction Ratio	ER	6	-	-	dB
Output Optical Eye		Compliant With IEEE Std 802.3ba-2010			

Parameter	Symbol	Min	Typ.	Max	Unit
Receiver					
Centre Wavelength	λ_c	1264.5	1271	1277.5	nm
		1284.5	1291	1297.5	
		1304.5	1311	1317.5	

		1324.5	1331	1337.5	
Receiver Sensitivity*note5	SEN	-	-	-11.5	dBm
Receiver Overload	P _{max}	2.3	-	-	dBm
LOS De-Assert	LOS _D	-	-	-11.5	dBm
LOS Assert	LOS _A	-20	-	-	dBm
LOS Hysteresis	LOS _H	0.5	-	5	dB

Note5: Measured with a PRBS 2³¹-1 test pattern @10.3125Gbps, BER≤10⁻¹².

40G ER4

Parameter	Symbol	Min	Typ.	Max	Unit
Transmitter					
Centre Wavelength	λ_c	1264.5	1271	1277.5	nm
		1284.5	1291	1297.5	
		1304.5	1311	1317.5	
		1324.5	1331	1337.5	
Spectral Width (-20dB)	$\Delta\lambda$	-	-	1	nm
Transmitter Signal Rate			10.3125		Gbps
SMSR		30			dB
TDP, each Lane	TDP			2.6	dB
Optical Return Loss Tolerance	TOL			20	dB
Average Output Power	P _{out}	-3.7	-	4.5	dBm
Extinction Ratio	ER	5.5	-	-	dB
Output Optical Eye*note6		0.25,0.4,0.45,0.25,0.28,0.4			

Parameter	Symbol	Min	Typ.	Max	Unit
Receiver					
Centre Wavelength	λ_c	1264.5	1271	1277.5	nm
		1284.5	1291	1297.5	
		1304.5	1311	1317.5	
		1324.5	1331	1337.5	
Receiver Sensitivity*note5	SEN	-	-	-18	dBm
Receiver Overload	P _{max}	3.8	-	-	dBm
LOS De-Assert	LOS _D	-	-	-19	dBm
LOS Assert	LOS _A	-30	-	-	dBm
LOS Hysteresis	LOS _H	0.5	-	5	dB

Note6: Measured with a PRBS 2³¹-1 test pattern @10.3125Gbps, Hit ratio≤ 5E-5.

QSFP+ Transceiver Electrical Pad Layout

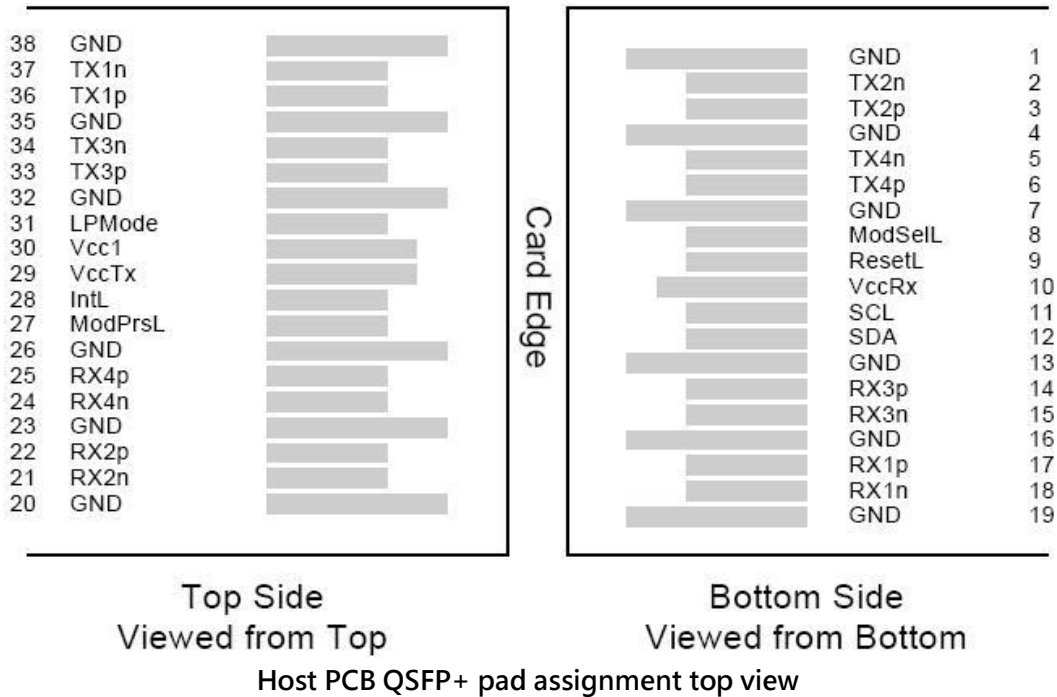

Pin Function Definitions

PIN	Logic	Symbol	Name/Description	Note
1		GND	Ground	1
2	CML-I	Tx2n	Transmitter Inverted Data Input	
3	CML-I	Tx2p	Transmitter Non-Inverted Data output	
4		GND	Ground	1
5	CML-I	Tx4n	Transmitter Inverted Data Input	
6	CML-I	Tx4p	Transmitter Non-Inverted Data output	
7		GND	Ground	1
8	LVTTLL-I	ModSelL	Module Select	
9	LVTTLL-I	ResetL	Module Reset	
10		VccRx	+ 3.3V Power Supply Receiver	2
11	LVC MOS-I/O	SCL	2-Wire Serial Interface Clock	
12	LVC MOS-I/O	SDA	2-Wire Serial Interface Data	
13		GND	Ground	
14	CML-O	Rx3p	Receiver Non-Inverted Data Output	
15	CML-O	Rx3n	Receiver Inverted Data Output	
16		GND	Ground	1
17	CML-O	Rx1p	Receiver Non-Inverted Data Output	
18	CML-O	Rx1n	Receiver Inverted Data Output	
19		GND	Ground	1
20		GND	Ground	1
21	CML-O	Rx2n	Receiver Inverted Data Output	
22	CML-O	Rx2p	Receiver Non-Inverted Data Output	
23		GND	Ground	1
24	CML-O	Rx4n	Receiver Inverted Data Output	1
25	CML-O	Rx4p	Receiver Non-Inverted Data Output	

26		GND	Ground	1
27	LVTTL-O	ModPrsL	Module Present	
28	LVTTL-O	IntL	Interrupt	
29		VccTx	+3.3 V Power Supply transmitter	2
30		Vcc1	+3.3 V Power Supply	2
31	LVTTL-I	LPMode	Low Power Mode	
32		GND	Ground	1
33	CML-I	Tx3p	Transmitter Non-Inverted Data Input	
34	CML-I	Tx3n	Transmitter Inverted Data Output	
35		GND	Ground	1
36	CML-I	Tx1p	Transmitter Non-Inverted Data Input	
37	CML-I	Tx1n	Transmitter Inverted Data Output	
38		GND	Ground	1

Note1. GND is the symbol for signal and supply (power) common for QSFP modules. All are common within the QSFP module and all module voltages are referenced to this potential unless otherwise noted. Connect these directly to the host board signal common ground plane.

Note2. VccRx, Vcc1 and VccTx are the receiver and transmitter power suppliers and shall be applied concurrently.

Recommended host board power supply filtering is shown below. Vcc Rx, Vcc1 and Vcc Tx may be internally connected within the QSFP transceiver module in any combination. The connector pins are each rated for a maximum current of 500mA.

Digital Diagnostic Functions

2-wire serial address, 1010000x (A0h)*

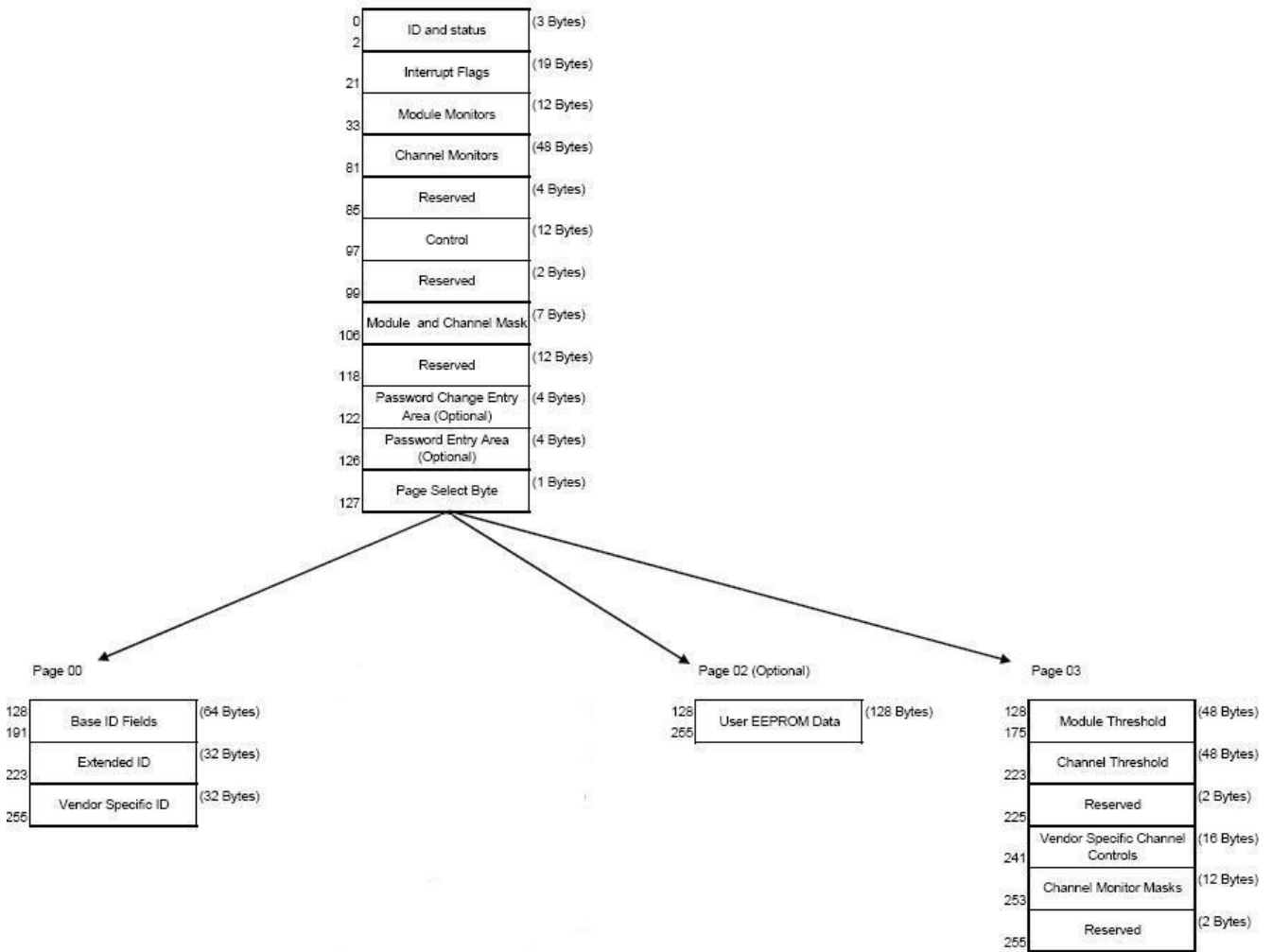

Digital Diagnostic Memory Map Specific Data Field Descriptions

Recommended Circuit

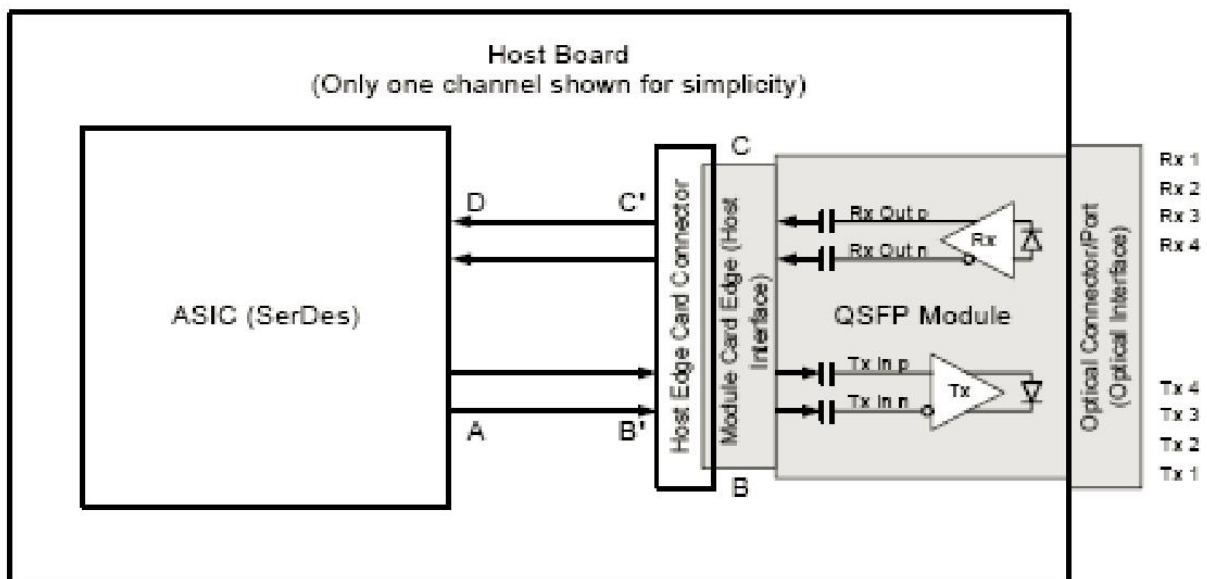

Mechanical Dimension

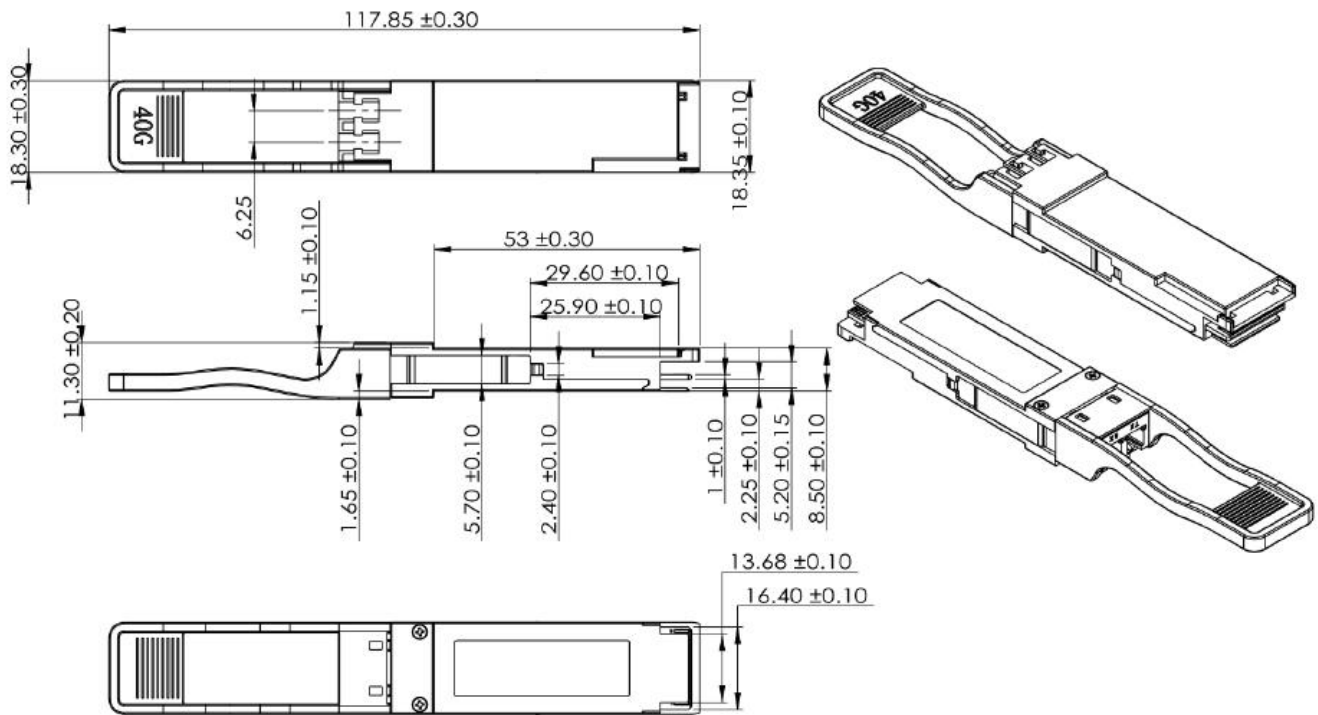

Eye Safety

These transceivers are Class 1 laser products. It complies with IEC-60825 and FDA 21 CFR 1040.10 and 1040.11. The transceiver must be operated within the specified temperature and voltage limits. The optical ports of the module shall be terminated with an optical connector or with a dust plug.

Obtaining Document

You can visit our website: <http://www.trixontech.com>

Or contact Trixon Inc. listed at the end of the documentation to get the latest document.

Notice

Trixon reserves the right to make changes to or discontinue any optical link product or service identified in this publication, without notice, in order to improve design and/or performance.

Applications that are described herein for any of the optical link products are for illustrative purposes only. Trixon makes no representation or warranty that such applications will be suitable for the specified use without further testing or modification.

Add: # 202, Section A, Building 1 No.209, Sanshe Road, Jinjiang District Industry Park Chengdu

610063. Sichuan P.R. CHINA

Tel: (+86) 028-85925400/Fax: (+86) 028-85925445

E-mail: info@trixontech.com

<http://www.trixontech.com>

© Copyright Trixon 2014 All rights reserved.

