

Features:

- Duplex LC optical connector
- SFP28 MSA compliant
- SFF-8431 compliant
- Hot-pluggable SFP footprint
- Built-in digital diagnostic functions
- Capable of over 10km transmission on single-mode fiber
- Single +3.3V power supply
- Operating case temperature: 0~70C
- RoHS-6 compliant

Applications:

- 25GBASE-LR

Product Description

The TPS-X510-31DCR is an 1310nm DFB 25Gigabit SFP28 transceiver. It is designed to transmit and receive optical data over 9/125 μ m single-mode optical fiber (SMF) and support up to 10km. The module has a duplex LC optical interface and all mechanical characteristics are compliant with the current SFP+ specification (SFF-8431 and SFF-8432).

Ordering information

Part No.	Data Rate	Laser	Fiber Type	Distance* ^{Note1}	Optical Interface	Temp.* ^{Note2}	DDMI
TPS-X510-31DCR	28Gbps	1310nm-DFB	SMF	10km	LC	ST	Y

Note1: 10km with 9/125µm SMF

Note2: ST: -5 ~ +70 deg C

Regulatory Compliance

Feature	Standard	Performance
Electrostatic Discharge (ESD) to the Electrical Pins	MIL-STD-883G Method 3015.7	HBM class 1, 1000volts and above, Contact discharge on Golden Finger.
Electrostatic Discharge to the enclosure	IEC-61000-4-2 GR-1089-CORE	Compliant with standards.
Electromagnetic Interference (EMI)	FCC Part 15 Class B EN55022:2006 VCCI Class B	Compliant with standards Noise frequency range: 30MHz to 18 GHz. System margins depend on customer host board and chassis design.
Immunity	IEC 61000-4-3	Compliant with standards.
Laser Eye Safety	FDA 21CFR 1040.10 and 1040.11 EN (IEC) 60825-1:2007 EN (IEC) 60825-2:2004+A1	CDRH compliant and Class I laser product.
Component Recognition	UL and CUL EN60950-1:2006	Compliant with standards.
RoHS6	2002/95/EC 4.1&4.2 2005/747/EC 5&7&13	Compliant with standards* ^{note3}

Note3:

In light of item 5 in RoHS exemption list of RoHS Directive 2002/95/EC, Item 5: Lead in glass of cathode ray tubes, electronic components and fluorescent tubes.

In light of item 13 in RoHS exemption list of RoHS Directive 2005/747/EC, Item 13: Lead and cadmium in optical and filter glass. The three exemptions are being concerned for Trixon transceivers, because Trixon transceivers use glass, which may contain Pb, for components such as lenses, windows, isolators, and other electronic components.

Absolute Maximum Ratings*^{Note4}

Parameter	Symbol	Min	Max	Unit
Storage Temperature	Tst	-20	85	degC
Relative Humidity (non-condensation)	RH	-	85	%
Supply Voltage	VCC	-0.5	3.6	V
Voltage on LVTTTL Input	Vilvttl	-0.5	VCC+0.5	V
LVTTTL Output Current	Iolvttl	-	15	mA
Voltage on Open Collector Output	Voco	0	6	V

Note4: Exceeding any one of these values may destroy the device permanently.

Recommended Operating Conditions

Parameter	Symbol	Min	Typical	Max	Unit	Notes
Operating Case Temperature	Topc	0	-	70	°C	
Power Supply Voltage	VCC	3.1	-	3.5	V	
Operating Relative Humidity	OH	5	-	95	%	
Supply Current	Is	-	-	300	mA	
Fiber Length			-	10	km	

Performance Specifications – Electrical

Parameter	Symbol	Min	Typ.	Max	Unit	Notes
Data Rate, each Lane		-	-	28	Gbps	
Control I/O Voltage, High	VIH	2.0	-	VCC	V	
Control I/O Voltage, Low	VIL	0	-	0.8	V	
Tx Input Diff Voltage	VI	180	-	700	mV	
Tx Input Diff Impedance	ZIN	90	100	110	Ω	
Rx Output Diff Voltage	Vo	300		900	mV	
Rx Output Diff Impedance	ZOUT	90	100	110	Ω	

Performance Specifications – Optical

Parameter	Symbol	Min	Typ.	Max	Unit
Transmitter					
Center Wavelength	λ_t	1295	1310	1325	nm
Spectral Width(-20dB)	Pm	-	-	1	nm
Average Optical Power, each Lane	Pavg	-5	-	+3.5	dBm
TDP, each Lane		-	-	3.2	dB
Extinction Ratio	ER	3.5	-	-	dB
Receiver					
Center Wavelength	λ_r	1260	1310	1355	nm
Average Power at Receiver Input, each Lane			-	-10.4	dBm
Receiver Overload		3	-		dBm
LOSS De-Assert	LOSSd		-	-17	dBm
LOSS Assert	LOSSa	-30	-		dBm
LOSS Hysteresis		0.5	-		dB

Pin Descriptions

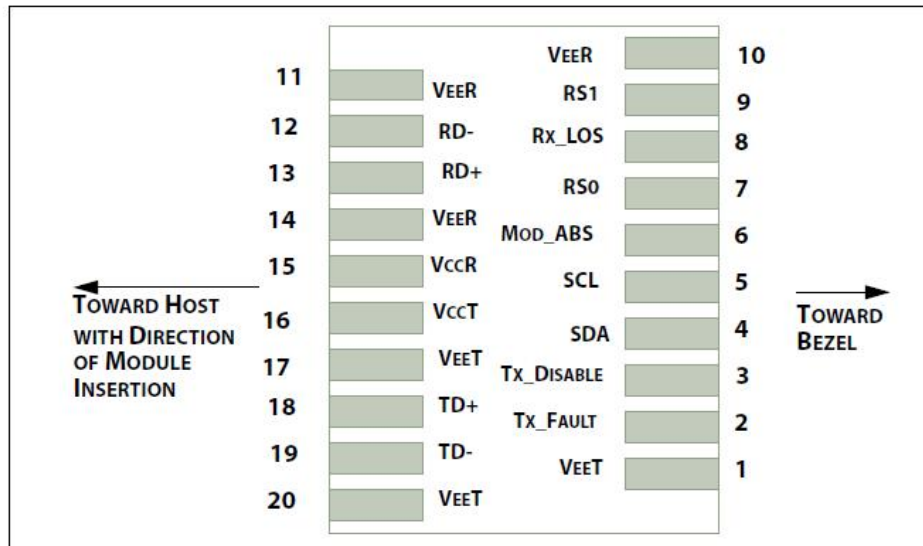

Pin Function Definitions

Pin Num.	Name	Function	Plug Seq.	Notes
1	VeeT	Transmitter Ground	1	Note 9
2	TX Fault	Transmitter Fault Indication	3	Note 5
3	TX Disable	Transmitter Disable	3	Note 6, Module disables on high or open.
4	SDA	Module Definition 2	3	2-wire Serial Interface Data Line.
5	SCL	Module Definition 1	3	2-wire Serial Interface Clock.
6	MOD-ABS	Module Definition 0	3	Note 7
7	RS0	RX Rate Select (LVTTTL).	3	Rate Select 0, optionally controls SFP+ module receiver. This pin is pulled low to VeeT with a >30K resistor..
8	LOS	Loss of Signal	3	Note 8
9	RS1	TX Rate Select (LVTTTL).	1	Rate Select 1, optionally controls SFP+ module transmitter. This pin is pulled low to VeeT with a >30K resistor
10	VeeR	Receiver Ground	1	Note 9
11	VeeR	Receiver Ground	1	Note 9
12	RD-	Inv. Received Data Out	3	Note 10
13	RD+	Received Data Out	3	Note 10
14	VeeR	Receiver Ground	1	Note 9
15	VccR	Receiver Power	2	3.3V ± 5%, Note 11
16	VccT	Transmitter Power	2	3.3V ± 5%, Note 11
17	VeeT	Transmitter Ground	1	Note 9
18	TD+	Transmit Data In	3	Note 12
19	TD-	Inv. Transmit Data In	3	Note 12
20	VeeT	Transmitter Ground	1	Note 9

Note5: TX Fault is an open collector/drain output, which should be pulled up with a 4.7K – 10K_Ω resistor on the host board. Pull up voltage between 2.0V and VccT/R+0.3V. When high, output indicates a laser fault of some kind. Low indicates normal operation. In the low state, the output will be pulled to < 0.8V.

Note6: TX disable is an input that is used to shut down the transmitter optical output. It is pulled up within the module with a

4.7K – 10 K_ resistor. Its states are: Low: Transmitter on; High: Transmitter Disabled; Open: Transmitter Disabled.

Note7: Module Absent, connected to VeeT or VeeR in the module.

Note8: LOS (Loss of Signal) is an open collector/drain output, which should be pulled up with a 4.7K –10K_ resistor. Pull up voltage between 2.0V and $V_{ccT}/R+0.3V$. When high, this output indicates the received optical power is below the worst-case receiver sensitivity (as defined by the standard in use). Low indicates normal operation. In the low state, the output will be pulled to $< 0.8V$.

Note9: The module signal ground contacts, VeeR and VeeT, should be isolated from the module case.

Note10: RD-/+: These are the differential receiver outputs. They are AC coupling that is done inside the module and is thus not required on the host board.

Note11: VccR and VccT are the receiver and transmitter power supplies. They are defined as $3.3V \pm 5\%$ at the SFP connector pin. Inductors with DC resistance of less than 1 ohm should be used in order to maintain the required voltage at the SFP input pin with 3.3V supply voltage. VccR and VccT may be internally connected within the SFP transceiver module.

Note12: TD-/+: These are the differential transmitter inputs. They are AC-coupled that is done inside the module and is thus not required on the host board.

Application Reference Diagram

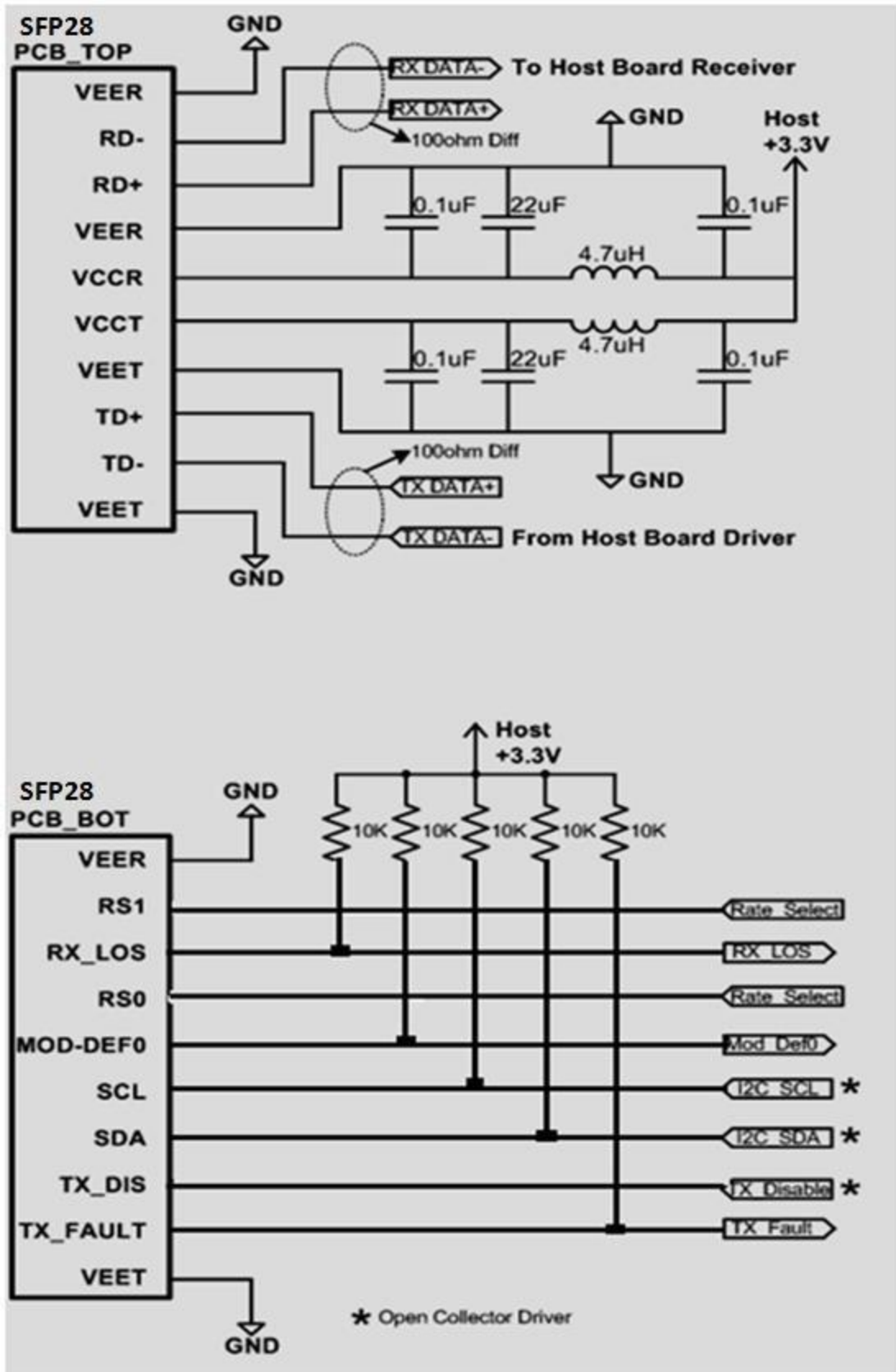

Mechanical Dimension

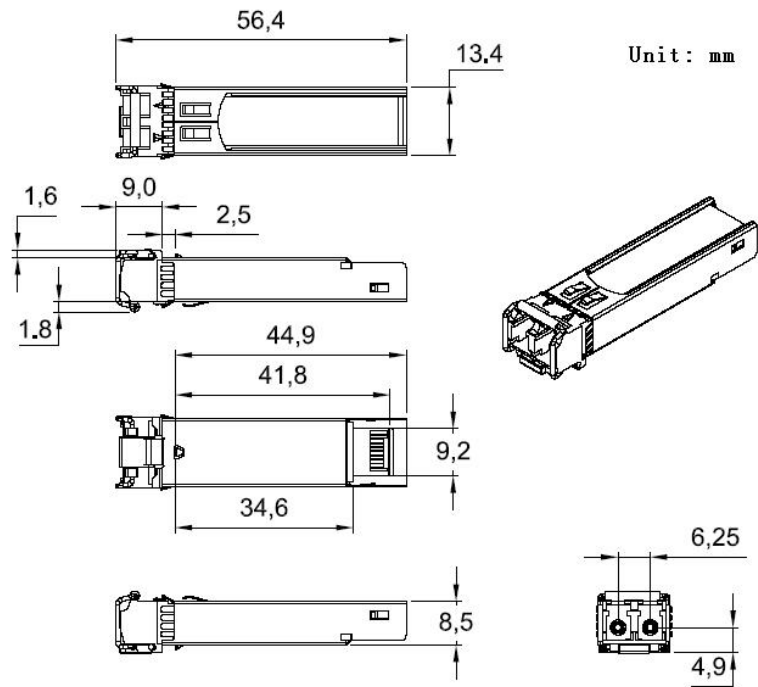

Eye Safety

These transceivers are Class 1 laser products. It complies with IEC-60825 and FDA 21 CFR 1040.10 and 1040.11. The transceiver must be operated within the specified temperature and voltage limits. The optical ports of the module shall be terminated with an optical connector or with a dust plug.

Obtaining Document

You can visit our website: <http://www.trixontech.com>

Or contact Trixon Inc. listed at the end of the documentation to get the latest document.

Notice

Trixon reserves the right to make changes to or discontinue any optical link product or service identified in this publication, without notice, in order to improve design and/or performance.

Applications that are described herein for any of the optical link products are for illustrative purposes only. Trixon makes no representation or warranty that such applications will be suitable for the specified use without further testing or modification.

Add: # 202, Section A, Building 1 No.209, Sanshe Road, Jinjiang District Industry Park Chengdu
610063. Sichuan P.R. CHINA

Tel: (+86) 028-85925400/Fax: (+86) 028-85925445

E-mail: info@trixontech.com

<http://www.trixontech.com>

© Copyright Trixon 2014 All rights reserved.

