

CFP2-LR4 Receiver

100G-BASE 10km CFP2



Features:

- Hot pluggable CFP2 MSA package
- 3.3V Power supply and MDIO management interface for digital diagnostics
- LC Connector Interface
- Integrated 4-LAN WDM ROSA for up to 10km link over G.652 SMF
- Operating data rate at 103.125Gbps or 112Gbps
- MSA-CFP2 Specification compliant
- Operating Case Temperature: 0 ~ +70°C
- Power consumption less than 3W

Applications:

- 100GBase-LR4 Ethernet
- OTU4 4I1-9D1F

Product Description

TC2-HG10-31DCR-R CFP2 receivers are designed for use in 100 Gigabit Ethernet links over 10km single module fiber, and it compliant to the CFP2 MSA and IEEE 802.3ba 100GBASE-LR4. Digital diagnostics are available via MDIO as specified in the CFP2 MSA Management Interface Specification. The module's designs are optimized for high performance and cost efficiency to provide customers the best solutions for Datacom and Telecom applications. The transceiver is RoHS-6 compliant and lead-free per Directive 2002/95/EC.

Ordering information

Part No.	Data Rate	Laser	Fiber Type	Distance ^{*Note1}	Optical Interface	Bail color	Temp. ^{*Note2}	DDMI
TC2-HG10-31DCR-R	112Gbps		SMF	10km	LC	Blue	ST	YES

Note1: 10km with 9/125µm SMF

Note2: ST: 0 ~ +70deg C

Regulatory Compliance

Feature	Standard	Performance
Electrostatic Discharge (ESD) to the Electrical Pins	MIL-STD-883G Method 3015.7	Class 1C (>1000 V)
Electrostatic Discharge to the enclosure	EN 55024:1998+A1+A2 IEC-61000-4-2 GR-1089-CORE	Compliant with standards
Electromagnetic Interference (EMI)	FCC Part 15 Class B EN55022:2006 CISPR 22B :2006 VCCI Class B	Compliant with standards Noise frequency range: 30 MHz to 6 GHz. Good system EMI design practice required to achieve Class B margins. System margins depend on customer host board and chassis design.
Immunity	EN 55024:1998+A1+A2 IEC 61000-4-3	Compliant with standards. 1kHz sine-wave, 80% AM, from 80 MHz to 1 GHz. No effect on transmitter/receiver performance is detectable between these limits.
Laser Eye Safety	FDA 21CFR 1040.10 and 1040.11 EN (IEC) 60825-1:2007 EN (IEC) 60825-2:2004+A1 EN (IEC) 60950-1:2006+A1+A11+A12	CDRH compliant and Class I laser product. TUV Certificate No. R50271605
Component Recognition	UL and CUL EN60950-1:2006	TUV Certificate No. E344594 (CB:JPTUV-053877)
RoHS2.0	20011/65/EU	Compliant with standards

Absolute Maximum Ratings^{*Note3}

Parameter	Symbol	Min	Max	Unit
Storage Temperature	TS	-40	+85	°C
Supply Voltage	V _{CC}	-0.3	3.6	V
Operating Humidity	-	5	85	%

Note3: Exceeding any one of these values may destroy the device permanently.

Recommended Operating Conditions

Parameter	Symbol	Min	Typical	Max	Unit
Operating Case Temperature	T _c	0		70	°C

Power Supply Voltage	V_{CC}	3.14	3.3	3.47	V
Bit Rate			103.125		Gbps
Supply Current	I_{CC}			3560	mA
Power dissipation	P			9	W
Low Power dissipation	P_{Low}			2	W
In-rush Current				200	mA/us
Turn-off rush Current		-200			mA/us

Performance Specifications – Electrical

Parameter	Symbol	Min	Typ.	Max	Unit	Notes
3.3V LVCOMS						
Input High Voltage	V_{IH}	2		$V_{CC}+0.3$	V	
Input Low Voltage	V_{IL}	-0.3		0.8	V	
Input Leakage Current	I_{IN}	-10		10	mA	
Output High Voltage ($I_{OH} = -100\mu A$)	V_{OH}	$V_{CC}-0.2$		$V_{CC}+0.3$	V	
Output Low Voltage ($I_{OL} = 100\mu A$)	V_{OL}	-0.3		0.2	V	
Minimum Pulse Width of Control Pin Signal	t_{CNTL}	100			us	
1.2V CMOS						
Input High Voltage	V_{IH}	0.84		1.5	V	
Input Low Voltage	V_{IL}	-0.3		0.36	V	
Input Leakage Current	I_{IN}	-100		100	μA	
Output High Voltage	V_{OH}	1	-	1.5	V	
Output Low Voltage	V_{OL}	-0.3		0.2	V	
Output High Current	I_{OH}			-4	mA	
Output Low Current	I_{OL}	4			mA	
Input capacitance	C_i			10	pF	
Reference Clock						
Impedance	Z_d	85	100	115	ohm	
Output Differential Voltage	V_{diff}			900	mV	

Timing Specifications

Parameter	Symbol	Min	Typ.	Max	Unit
Receiver Loss of Signal Assert Time	t_{loss_assert}			100	us
Receiver Loss of Signal De-Assert Time	$t_{loss_deassert}$			100	us
Global Alarm Assert Delay Time	GLB_ALRMn_assert			150	ms
Global Alarm De-Assert	$GLB_ALRMn_deassert$			150	ms

Delay Time				
Host MDIO t_setup	t_setup	10		
Host MDIO t_hold	t_hold	10		
CFP2 MDIO t_delay	t_delay	0	175	
Initialization time from Reset	t_initialize		2.5	s
Management Interface Clock Frequency	F_MDC	0.1	4	MHz
Management Interface Clock Period	t_prd	250	10000	ns
MDC high and low time	twidth	40	60	%
		160		ns
MDIO/MDC termination in CFP2	Zt	100		kOhm

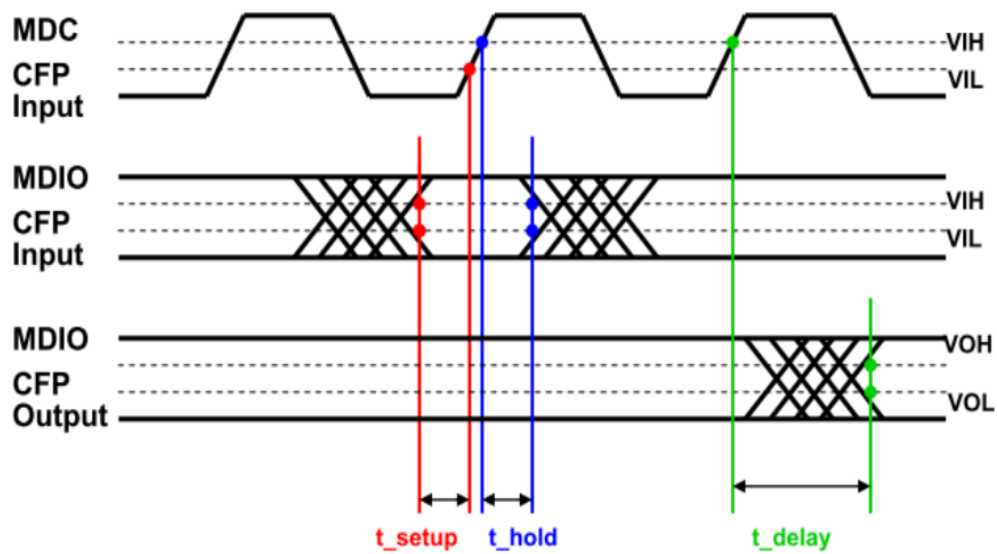

Figure 1. 100 Gb/s CFP2 MDIO & MDC Timing Diagram

Performance Specifications – Optical

(100GBASE LR4)

Parameter	Symbol	Min	Typ.	Max	Unit	Note
Receiver						
Channel data rate			25.7812		Gbps	
Data rate variation		-100		100	ppm	
Centre Wavelength	λ_{CT0}	1294.53	1295.56	1296.59	nm	
	λ_{CT1}	1299.02	1300.05	1301.09	nm	
	λ_{CT2}	1303.54	1304.58	1305.63	nm	
	λ_{CT3}	1308.09	1309.14	1310.19	nm	
Damage threshold		5.5			dBm	
Average receiver power per lane	Pin	-10.6		4.5	dBm	
Receiver Sensitivity(OMA) per lane	Psen			-8.6	dBm	
Stressed Receiver Sensitivity per Lane	Psen_str			-6.8	dBm	

Receiver Reflectance	Ref	-26	dB		
Rx-Lane LOS Assert		-21	-17	-16	dBm
Rx-Lane LOS De-assert			-16	-15	dBm
Rx-Lane LOS Hysteresis		0.5			dB

(OTU4 4I1-9D1F)

Parameter	Symbol	Min	Typ.	Max	Unit	Note
Receiver						
Channel data rate			27.95		Gbps	
Data rate variation		-20		20	ppm	
Centre Wavelength	λ_{CT0}	1294.53	1295.56	1296.59	nm	
	λ_{CT1}	1299.02	1300.05	1301.09	nm	
	λ_{CT2}	1303.54	1304.58	1305.63	nm	
	λ_{CT3}	1308.09	1309.14	1310.19	nm	
Damage threshold	λ_c	5.5			dBm	
Average receiver power per lane	Pin	-8.8		4.0	dBm	
Equivalent Sensitivity per lane	Psen			-10.3	dBm	
Receiver Reflectance	Ref			-26	dB	
Rx-Lane LOS Assert		-21	-17	-16	dBm	
Rx-Lane LOS De-assert			-16	-15	dBm	
Rx-Lane LOS Hysteresis		0.5			dB	

Internal reference structure

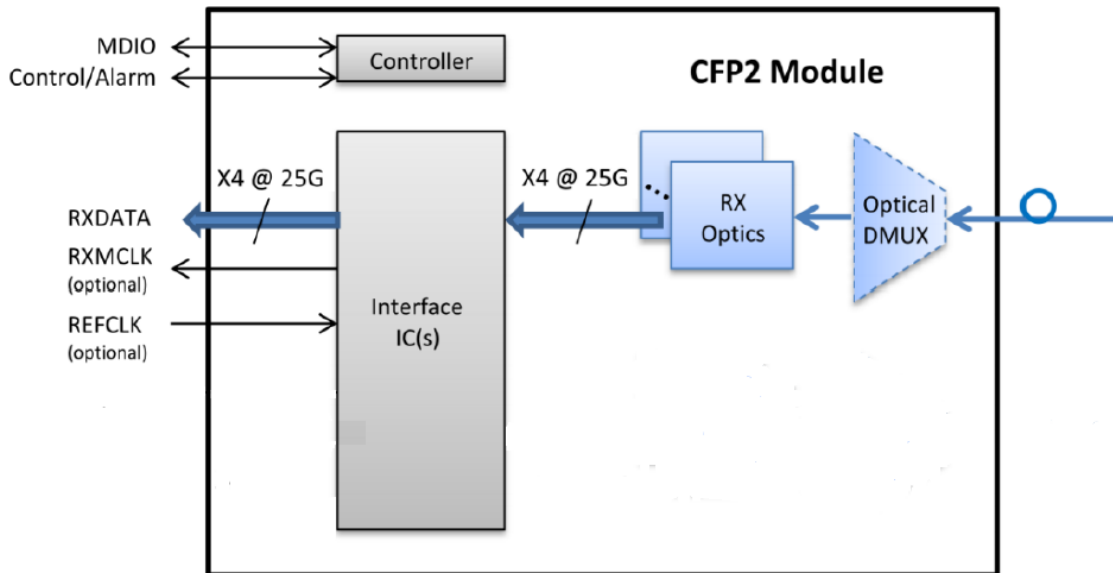

Figure 2. 10km 100Gb/s CFP2 internal structure

Pin Layout

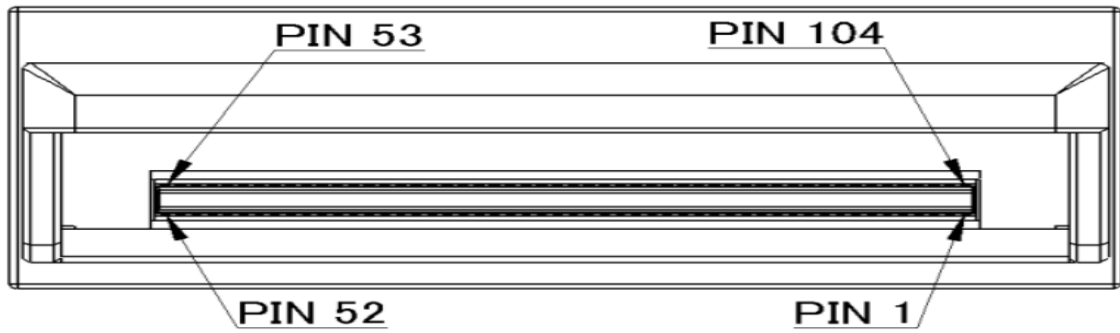

Figure 5. CFP2 Module Pad Layout

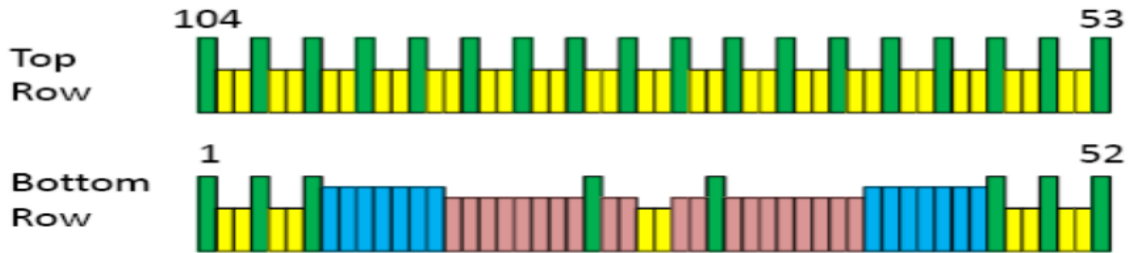

Figure 6. CFP2 Pin Map Connector

	Bottom Row	Bottom Row		Top Row	Top Row
1	GND	52	3.3V_GND	53	GND
2	N.C.	51	(RX_MCLKp)	54	N.C.
3	N.C.	50	(RX_MCLKn)	55	N.C.
4	GND	49	3.3V_GND	56	GND
5	N.C.	48	N.C.	57	RX0p
6	N.C.	47	N.C.	58	RX0n
7	3.3V_GND	46	3.3V_GND	59	GND
8	3.3V_GND	45	3.3V_GND	60	RX1p
9	3.3V	44	3.3V	61	RX1n
10	3.3V	43	3.3V	62	GND
11	3.3V	42	3.3V	63	N.C.
12	3.3V	41	3.3V	64	N.C.
13	3.3V_GND	40	3.3V_GND	65	GND
14	3.3V_GND	39	3.3V_GND	66	N.C.
15	VND_IO_A	38	VND_IO_E	67	N.C.
16	VND_IO_B	37	VND_IO_D	68	GND
17	PRG-CNTL1	36	VND_IO_C	69	RX2p
18	PRG-CNTL2	35	PRTADR2	70	RX2n
19	PRG-CNTL3	34	PRTADR1	71	GND
20	PRG-ALRM1	33	PRTADR0	72	RX3p
21	PRG-ALRM2	32	MDIO	73	RX3n
22	PRG-ALRM3	31	MDC	74	GND
23	GND	30	GND	75	N.C.
24	N.C.	29	MOD_ALRMN	76	N.C.
25	RX_LOS	28	MOD_RSTn	77	GND
26	MOD_LOPWR	27	MOD_ADS	78	(REFCLKp)
				79	(REFCLKn)

Figure 7. CFP2 Module Pin Map ^{*Note4}

Note4: Pin 15, 16, 36, 37, 38, are internally used and NOT allowed to connect any signal and power supply or GND;
Pin 2, 3, 50, 51 are disabled unless MCLK output is enabled via MDIO.

Pin Function Definitions

Pin Num.	Name	Function	I/O	LOGIC
1,4,23,30,49 52,53,56,59,62 65,68,71,74,77 80,83,86,89,92 95,98,101,104	GND			
2,3,5,6,24,47,48,54 55,63,64,66,67 75,76,81,82,84,85,87,88,90 91,93,94,96,97,99,100,102,103	N.C.	No Connect		
7,8,13,14, 39,40,45,46	3.3V_GND	3.3V Module Supply Voltage Return Ground, can be separate or tied together with Signal Ground		
9,10,11,12, 41,42,43,44	3.3V	3.3V Module Supply Voltage		
15	VND_IO_A	Module Vendor I/O. Must No Connect at host board	I/O	
16	VND_IO_B	Module Vendor I/O. Must No Connect at host board	I/O	
17	PRG_CNTL1	Programmable Control 1 set over MDIO, MSA Default: TRXIC_RSTn, TX & RX ICs reset, "0": reset, "1" or NC: enabled = not used , 4.75kohm pull up in the module	I	LVC MOS w/ PUR
18	PRG_CNTL2	Programmable Control 2 set over MDIO, MSA Default: Hardware Interlock LSB, "00": ≤8W, "01": ≤16W, "10": ≤24W, "11" or NC: ≤32W = not used ,4.75kohm pull up in the module	I	LVC MOS w/ PUR
19	PRG_CNTL3	Programmable Control 3 set over MDIO, MSA Default: Hardware Interlock MSB, "00": ≤8W, "01": ≤16W, "10": ≤24W, "11" or NC: ≤32W = not used ,4.75kohm pull up in the module	I	LVC MOS w/ PUR
20	PRG_ALRM1	Programmable Alarm 1 set over MDIO, MSA Default: HIPWR_ON, "1": module power up completed, "0": module not high powered up	O	LVC MOS
21	PRG_ALRM2	Programmable Alarm 2 set over MDIO, MSA Default: MOD_READY, "1": Ready, "0": not Ready.	O	LVC MOS
22	PRG_ALRM3	Programmable Alarm 3 set over MDIO, MSA Default: MOD_FAULT, fault detected, "1": Fault, "0": No Fault	O	LVC MOS
25	RX_LOS	Receiver Loss of Optical Signal, "1": low optical signal, "0": normal condition	O	LVC MOS
26	MOD_LOPWR	Module Low Power Mode. "1" or NC: module in low power (safe) mode, "0": power-on enabled 4.75kohm pull up in the module	I	LVC MOS w/ PUR

27	MOD_ABS	Module Absent. "1" or NC: module absent, "0": module present, Pull Up Resistor on Host	O	GND
28	MOD_RSTn	Module Reset. "0" resets the module, "1" or NC = module enabled, 4.75kohm Pull Down Resistor in Module	I	LVC MOS w/ PUR
29	GLB_ALRMn	Global Alarm. "0": alarm condition in any MDIO Alarm register, "1": no alarm condition, Open Drain, Pull Up Resistor on Host	O	LVC MOS
31	MDIO	Management Data I/O bi-directional data (electrical specs as per 802.3ae and 802.3ba)	I/O	1.2V COMS
32	MDC	Management Data Clock (electrical specs as per 802.3ae and 802.3ba)	I	1.2V COMS
33	PRTADR0	MDIO Physical Port address bit 0	I	1.2V COMS
34	PRTADR1	MDIO Physical Port address bit 1	I	1.2V COMS
35	PRTADR2	MDIO Physical Port address bit 2	I	1.2V COMS
50	VND_IO_C	Module Vendor I/O. Must No Connect at host board	I/O	
51	VND_IO_D	Module Vendor I/O. Must No Connect at host board	I/O	
53	VND_IO_E	Module Vendor I/O. Must No Connect at host board	I/O	
50	RX_MCLKn	RX Monitor Clock Output (Negative)	O	
51	RX_MCLKp	RX Monitor Clock Output (Positive)	O	
57	RX0p	Lane 0 Receiver Output (Positive)	O	HS I/O
58	RX0n	Lane 0 Receiver Output (Negative)	O	HS I/O
60	RX1p	Lane 1 Receiver Output (Positive)	O	HS I/O
61	RX1n	Lane 1 Receiver Output (Negative)	O	HS I/O
69	RX2p	Lane 2 Receiver Output (Positive)	O	HS I/O
70	RX2n	Lane 2 Receiver Output (Negative)	O	HS I/O
72	RX3p	Lane 3 Receiver Output (Positive)	O	HS I/O
73	RX3n	Lane 3 Receiver Output (Negative)	O	HS I/O
78	REFCLKp	Reference Clock Input (Positive)	I	
79	REFCLKn	Reference Clock Input (Negative)	I	

Management Interface

TC2-HG10-31DCR-R CFP2 Receivers supports the MDIO interface specified in IEEE802.3 Clause 45. This 2-wire management data I/O interface is provided for the module status monitoring and control. The management data clock (MDC) provides clocking for the data that is passed on the MDIO port. Three further pins allow for loading of a port address (PORT_ADDR0-2) into the module.

Mechanical Specifications

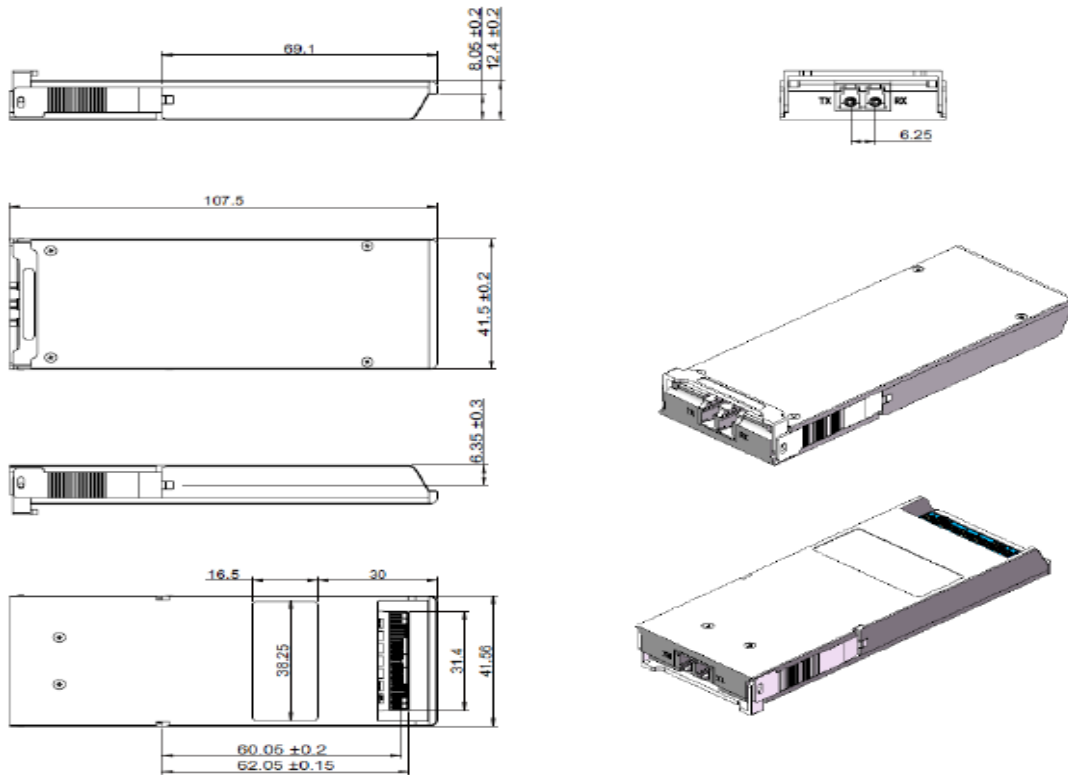

Eye Safety

This single-mode transceiver is a Class 1 laser product. It complies with IEC-60825 and FDA 21 CFR 1040.10 and 1040.11. The transceiver must be operated within the specified temperature and voltage limits. The optical ports of the module shall be terminated with an optical connector or with a dust plug.

Obtaining Document

You can visit our website: <http://www.trixontech.com>

Or contact Trixon Inc. listed at the end of the documentation to get the latest document.

Notice

Trixon reserves the right to make changes to or discontinue any optical link product or service identified in this publication, without notice, in order to improve design and/or performance.

Applications that are described herein for any of the optical link products are for illustrative purposes only. Trixon makes no representation or warranty that such applications will be suitable for the specified use without further testing or modification.

Add: # 202, Section A, Building 1 No.209, Sanshe Road, Jinjiang District Industry Park Chengdu 610063. Sichuan P.R. CHINA

Tel: (+86) 028-85925400/Fax: (+86) 028-85925445

E-mail: info@trixontech.com

<http://www.trixontech.com>

© Copyright Trixon 2015 all rights reserved.

