

# 10G CWDM SFP+ Transceiver With Digital Diagnostic Function



## Features:

- Single 3.3V Power supply and TTL Logic Interface
- Operating data rate at 10.3 Gb/s
- Hot Pluggable SFP+ MSA package
- Compliant with SFF-8431 and SFF-8432
- Compliant with 802.3ae 10GBASE-LR/ER/ZR
- Duplex LC Connector Interface
- Metal enclosure, for lower EMI
- Operating Case Temperature: 0°C ~+70°C
- Class 1 Laser International Safety Standard IEC-60825 compliant
- 1W maximum power consumption for DML

## Applications:

- 10GBASE-LR 10G Ethernet
- 10GBASE-ER 10G Ethernet
- 3G/4G/5G

## Product Description

The CWDM SFP+ Series optical transceivers are designed for use in 10G CWDM networks. It's complying with SFF-8431, SFF-8432, and 10-Gigabit Ethernet IEEE802.3ae. This module is designed for single mode fiber and operates at a nominal wavelength of CWDM wavelength. There are 18 center wavelengths available from 1270nm to 1610nm, with each step 20nm. Digital diagnostics are available via 2-wire serial interface as specified in the SFF-8472. The transceiver is RoHS 2.0 compliant and lead-free per Directive 2011/65/EU.

## Ordering information

Part No. <sup>*Note1</sup>	Data Rate	Laser	Fiber Type	Power Budget (dB)	Optical Interface	TEMP	DDMI
TPC-TG10-XXDCR	10.3G	CWDM DFB	SMF	14.5dB (Lower power)	LC	C	YES

Note1: XX refers to CWDM Wavelength range from 1271nm to 1571nm.

## Regulatory Compliance

Feature	Standard	Performance
Electrostatic Discharge (ESD) to the Electrical Pins	MIL-STD-883G Method 3015.7	Class 1C (>1000 V)
Electrostatic Discharge to the enclosure	EN 55024:1998+A1+A2 IEC-61000-4-2 GR-1089-CORE	Compliant with standards
Electromagnetic Interference (EMI)	FCC Part 15 Class B EN55022:2006 CISPR 22B :2006 VCCI Class B	Compliant with standards Noise frequency range: 30 MHz to 6 GHz. Good system EMI design practice required to achieve Class B margins. System margins depend on customer host board and chassis design.
Immunity	EN 55024:1998+A1+A2 IEC 61000-4-3	Compliant with standards. 1kHz sine-wave, 80% AM, from 80 MHz to 1 GHz. No effect on transmitter/receiver performance is detectable between these limits.
Laser Eye Safety	FDA 21CFR 1040.10 and 1040.11 EN (IEC) 60825-1:2007 EN (IEC) 60825-2:2004+A1 EN (IEC) 60950-1:2006+A1+A11+A12	CDRH compliant and Class I laser product. TUV Certificate No. <a href="#">R50271605</a>
Component Recognition	UL and CUL EN60950-1:2006	TUV Certificate No. <a href="#">E344594</a> (CB:JPTUV-053877)
RoHS2.0	2011/65/EU	Compliant with standards

## Absolute Maximum Ratings<sup>\*Note2</sup>

Parameter	Symbol	Min	Max	Unit
Storage Temperature	T <sub>s</sub>	-40	+85	°C
Supply Voltage	V <sub>CC</sub>	0	3.6	V
Operating Humidity	-	5	85	%

Note2: Exceeding any one of these values may destroy the device permanently.

## Recommended Operating Conditions

Parameter	Symbol	Min	Typical	Max	Unit	Notes
-----------	--------	-----	---------	-----	------	-------

Operating Case Temperature	Tc	0	70	°C		
Power Supply Voltage	V <sub>CC</sub>	3.14	3.3	3.47	V	
Supply Current	I <sub>CC</sub>			300	mA	DML
				600	mA	EML

## Performance Specifications – Electrical

Parameter	Symbol	Min	Typ.	Max	Unit	Notes
<b>Transmitter</b>						
CML Inputs(Differential)	V <sub>in</sub>	180		1000	mVpp	AC coupled inputs
Input Impedance (Differential)	Z <sub>in</sub>		100		ohm	R <sub>in</sub> > 100 ohms @DC
Tx_DISABLE Input Voltage – High		2		V <sub>CC</sub> +0.3	V	
Tx_DISABLE Input Voltage – Lo		0		0.8	V	
Tx_FAULT Output Voltage – High		2		V <sub>CC</sub> +0.3	V	
Tx_FAULT Output Voltage – Low		0		0.8	V	
<b>Receiver</b>						
CML Outputs (Differential)	V <sub>out</sub>	350		700	mVpp	AC coupled outputs
Output Impedance (Differential)	Z <sub>out</sub>		100		ohm	
Rx_LOS Output Voltage – High		2			V	OC output, should be pull up with 4.7K – 10 KΩ on the host board
Rx_LOS Output Voltage – Low		0		0.5	V	
MOD_DEF (0:2)	V <sub>OH</sub>	2.5			V	With Serial ID
	V <sub>OL</sub>	0		0.5	V	

## I/O Timing for Control & Status Functions Timing

Parameter	Symbol	Min	Typ.	Max	Unit
TX Disable Assert Time	t <sub>off</sub>			100	us
TX_DISABLE Negate Time	t <sub>on</sub>			2	ms
Time to initialize, include reset of TX_FAULT(DML)	t <sub>init</sub>			300	ms
	t <sub>init</sub>			90	S
Time to initialize, include reset of TX_FAULT(EML)					
TX Fault Assert Time (DML)	t <sub>fault</sub>			1	ms
TX Fault Assert Time (EML)	t <sub>fault</sub>			50	ms
TX Disable to reset	t <sub>reset</sub>	10			us
LOS Assert Time	t <sub>loss_on</sub>			100	us
LOS De-Assert Time	t <sub>loss_off</sub>			100	us

# Performance Specifications – Optical

( 10.3Gbps · 10km 14.5dB budget )

Parameter	Symbol	Min	Typ.	Max	Unit	Note
<b>Transmitter</b>						
Centre Wavelength	$\lambda_c$	XX-6.5	XX	XX+6.5	nm	XX:Note5
Spectral Width* <sup>Note3</sup>	$\Delta\lambda$			1	nm	
Average Output Power	P <sub>OUT</sub>	0		5	dBm	
Extinction Ratio	ER	3.5			dB	
Side Mode Suppression Ratio	SMSR	30			dB	
Average Power of OFF Transmitter	P <sub>OFF</sub>			-30	dBm	
Transmitter and Dispersion Penalty	TDP			TDP	dB	波长
				1		1271
				1		1291
				1		1311
				1		1331
				2		1351
				2		1371
				2.5		1391
				2.5		1411
				2.5		1431
				2.5		1451
				3		1471
				3		1491
				4		1511
				4		1531
4	1551					
4	1571					
Optical Return Loss Tolerance	ORLT	-	-	12	dB	
Output Optical Eye	Compliant with IEEE 802.3ae					
<b>Receiver</b>						
Centre Wavelength	$\lambda_c$	1260		1620	nm	
Sensitivity* <sup>Note4</sup>	P <sub>IN</sub>			-15	dBm	Note4
Receiver Overload	Overload	0.5			dBm	
Receiver Reflectance				-12	dB	
LOS Assert	LOSA	-30			dBm	
LOS De-Assert	LOSD			-17	dBm	
LOS Hysteresis		0.5		4	dB	

Note3: LD measured spectral width –20dB.

Note4: Minimum average optical power measured at the BER less than 1E-12@pattern is PRBS2<sup>31</sup>-1@ER=9dB.

Note5: ITU-T G.694.2 CWDM wavelength from 1271nm from 1611nm, each step 20nm

# SFP Transceiver Electrical Pad Layout

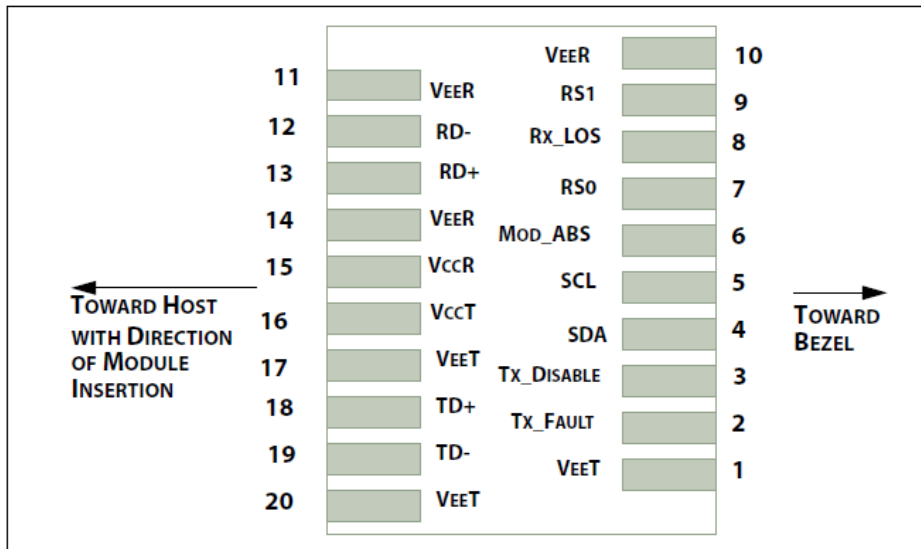

## Pin Function Definitions:

Pin Num.	Name	Function	Plug Seq.	Notes
1	VeeT	Transmitter Ground	1	Note 12
2	TX Fault	Transmitter Fault Indication	3	Note8
3	TX Disable	Transmitter Disable	3	Note 9, Module disables on high or open.
4	SDA	Module Definition 2	3	2-wire Serial Interface Data Line.
5	SCL	Module Definition 1	3	2-wire Serial Interface Clock.
6	MOD-ABS	Module Definition 0	3	Note 10
7	RS0	RX Rate Select (LVTTTL).	3	Rate Select 0, optionally controls SFP+ module receiver. This pin is pulled low to VeeT with a >30K resistor..
8	LOS	Loss of Signal	3	Note 11
9	RS1	TX Rate Select (LVTTTL).	1	Rate Select 1, optionally controls SFP+ module transmitter. This pin is pulled low to VeeT with a >30K resistor
10	VeeR	Receiver Ground	1	Note 12
11	VeeR	Receiver Ground	1	Note 12
12	RD-	Inv. Received Data Out	3	Note 13
13	RD+	Received Data Out	3	Note 14
14	VeeR	Receiver Ground	1	Note 12
15	VccR	Receiver Power	2	3.3V ± 5%, Note 14
16	VccT	Transmitter Power	2	3.3V ± 5%, Note 14
17	VeeT	Transmitter Ground	1	Note 12
18	TD+	Transmit Data In	3	Note 15
19	TD-	Inv. Transmit Data In	3	Note 15
20	VeeT	Transmitter Ground	1	Note 12

Note8: TX Fault is an open collector/drain output, which should be pulled up with a 4.7K – 10K\_ resistor on the host board. Pull up voltage between 2.0V and VccT/R+0.3V. When high, output indicates a laser fault of some kind. Low indicates normal operation. In the low state, the output will be pulled to < 0.8V.

Note9: TX disable is an input that is used to shut down the transmitter optical output. It is pulled up within the module with a 4.7K – 10 K\_ resistor. Its states are: Low (0 – 0.8V): Transmitter on (>0.8, < 2.0V): Undefined. High (2.0 – 3.465V): Transmitter

Disabled. Open: Transmitter Disabled.

Note10: Module Absent, connected to VeeT or VeeR in the module.

Note11: LOS (Loss of Signal) is an open collector/drain output, which should be pulled up with a 4.7K –10K<sub>Ω</sub> resistor. Pull up voltage between 2.0V and VccT/R+0.3V. When high, this output indicates the received optical power is below the worst-case receiver sensitivity (as defined by the standard in use). Low indicates normal operation. In the low state, the output will be pulled to < 0.5V.

Note12: The module signal ground contacts, VeeR and VeeT, should be isolated from the module case.

Note13: RD-/+ : These are the differential receiver outputs. They are AC coupled 100<sub>Ω</sub> differential lines which should be terminated with 100<sub>Ω</sub> (differential) at the user SERDES. The AC coupling is done inside the module and is thus not required on the host board.

Note14: VccR and VccT are the receiver and transmitter power supplies. They are defined as 3.3V ±5% at the SFP connector pin. Maximum supply current is 300mA. Inductors with DC resistance of less than 1 ohm should be used in order to maintain the required voltage at the SFP input pin with 3.3V supply voltage. When the recommended supply-filtering network is used, hot plugging of the SFP transceiver module will result in an inrush current of no more than 30mA greater than the steady state value. VccR and VccT may be internally connected within the SFP transceiver module.

Note15: TD-/+ : These are the differential transmitter inputs. They are AC-coupled, differential lines with 100<sub>Ω</sub> differential termination inside the module. The AC coupling is done inside the module and is thus not required on the host board.

## Digital Diagnostic Functions:

- 1) SFP transceiver supports the 2-wire serial communication protocol as defined in SFP MSA: in which defines a 256-byte memory map in EEPROM at 8 bit address 1010000X (A0h). The digital diagnostic monitoring interface be assigned with 8 bit address 1010001X (A2h). Additionally, SFP transceivers provide a unique digital diagnostic monitoring interface (DDMI), which allows real-time access to product operating parameters such as transceiver supply voltage, transceiver temperature, transmitted optical power, laser bias current and received optical power. It also defines alarm and warning threshold, which alerts end-users when particular operating parameters are outside of factory setting.
- 2) When the serial protocol is activated, the serial clock signal (SCL, Mod Def 1) is generated by the host. The positive edge clocks data into those segments of the EEPROM that are not write-protected. The negative edge clocks data from the SFP transceiver. The serial data signal (SDA, Mod Def 2) is bi-Directional for serial data transfer. The host uses SDA in conjunction with SCL to mark the start and end of serial protocol activation. The memories are organized as a series of 8-bit data words that can be addressed individually or sequentially.

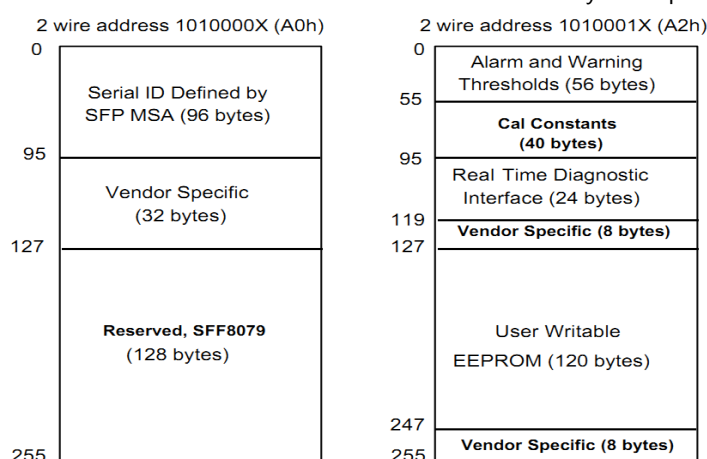

## Digital Diagnostic Monitoring Specifications

- 1) Additionally, SFP transceivers TPC-xxxx-xxDCR<sup>\*Note16</sup> provide a unique digital diagnostic monitoring interface (DDMI) be assigned with 8 bit address 1010001X (A2h) as defined in SFP MSA, which allows real-time access to product operating parameters such as transceiver supply voltage, transceiver temperature, transmitted optical power, laser bias current and received optical power. It also defines

alarm and warning threshold, which alerts end-users when particular operating parameters are outside of factory setting.

- 2) Digital diagnostics for the TPC-xxxx-xxDCR are internally calibrated by default. Calibration and alarm/warning threshold data is written during device manufacturing.

Monitor accuracy						
Parameter	Min	Typ	Max	Units		
Internally measured transceiver temperature			±3	°C		
Internally measured transceiver supply voltage			±3%	V		
Measured TX bias current			±10	%		
Measured TX output power			±3	dB		
Measured RX received average optical power			±3	dB		
Dynamic range for operation						
Parameter	H-Alarm	H-warning	L-Warnin g	L- Alarm	Units	Note
Internally measured transceiver temperature	+80	+73	-3	-10	°C	
Internally measured transceiver supply voltage	3.63	3.47	3.13	2.97	V	
Measured TX bias current	100	90	10	5	mA	
Measured TX output power	8.16	7.16	Pout_min-2	Pout_min-3	dBm	
Measured RX received average optical power	Overload+3	Overload+2	P <sub>IN</sub> -2	P <sub>IN</sub> -3	dBm	

Note16: TPC-xxxx-xxxxR provides an EEPROM addressed 1010000X (A0h) as defined in SFP MSA, and only TPC-xxxx-xxDCR is compliant with digital diagnostic monitoring interface (DDMI) be assigned with 8 bit address 1010001X (A2h) .

### Recommended Circuit

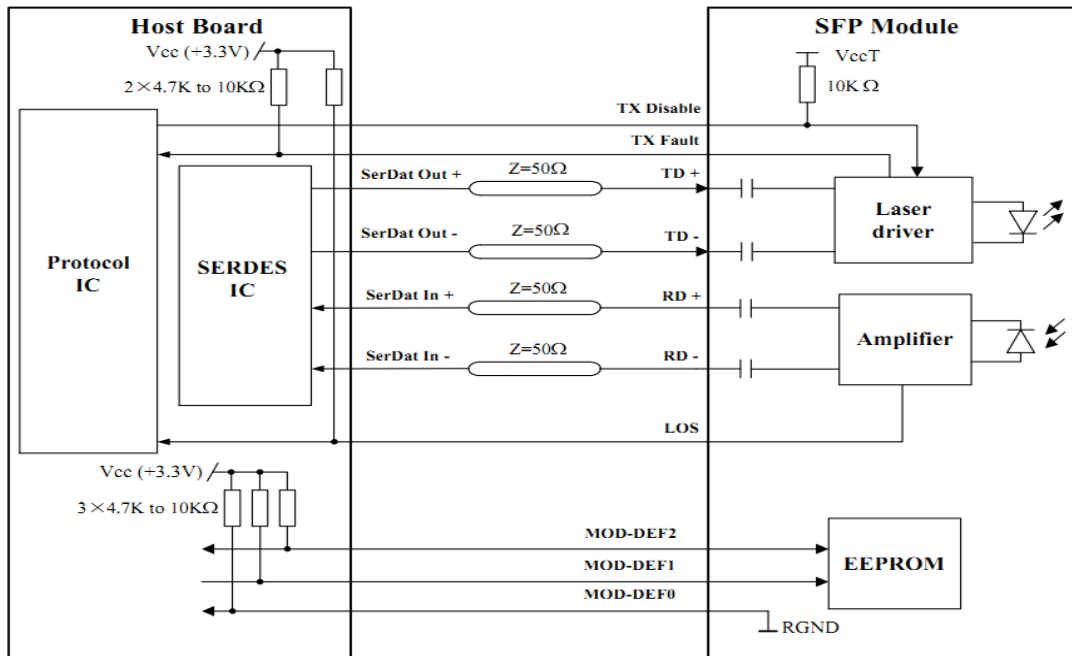

## Mechanical Dimension

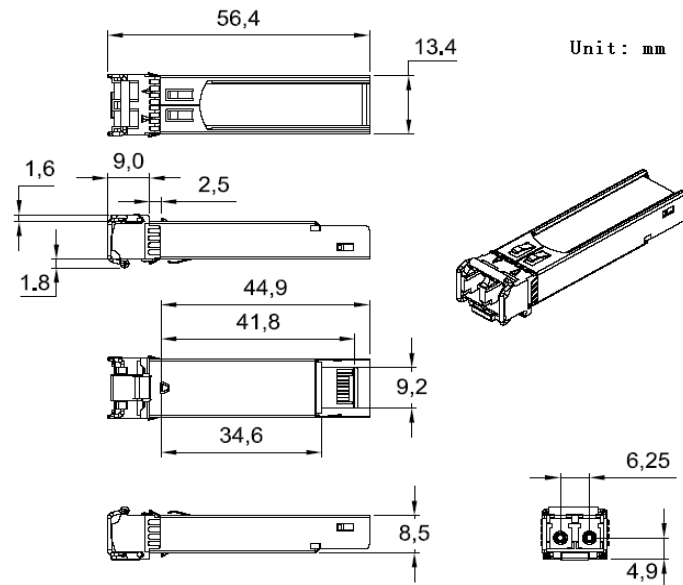

## Eye Safety

This single-mode transceiver is a Class 1 laser product. It complies with IEC-60825 and FDA 21 CFR 1040.10 and 1040.11. The transceiver must be operated within the specified temperature and voltage limits. The optical ports of the module shall be terminated with an optical connector or with a dust plug.

## Obtaining Document

You can visit our website: <http://www.trixontech.com>

Or contact Trixon Inc. listed at the end of the documentation to get the latest document.

## Notice

Trixon reserves the right to make changes to or discontinue any optical link product or service identified in this publication, without notice, in order to improve design and/or performance.

Applications that are described herein for any of the optical link products are for illustrative purposes only. Trixon makes no representation or warranty that such applications will be suitable for the specified use without further testing or modification.

Add: # 202, Section A, Building 1 No.209, Sanse Road, Jinjiang District Industry Park Chengdu  
610063. Sichuan P.R. CHINA

Tel: (+86) 028-85925400/Fax: (+86) 028-85925445

E-mail: [info@trixontech.com](mailto:info@trixontech.com)

<http://www.trixontech.com>

© Copyright Trixon 2014 all rights reserved.

