

10G Ethernet XFP Series

Datasheet



Features:

- Operating data rate is 10.3Gbps
- Distance up to 300m~80km
- 3.3V and 5V Power supply
- Duplex LC Connector Interface
- Hot Pluggable
- Compliant with MSA XFP Specification
- Compliant with Telcordia GR-253-CORE and IEEE802.3ae
- Digital Diagnostic Monitor Interface
Compatible with SFF-8077i
- Operating Case Temperature
Standard: -5°C ~ +70°C
Industrial: -40°C ~ +85°C

Applications:

- 10GBASE-SR/SW/LR/LW/ER/EW/ZR/ZW
- 10G Fiber Channel
- Other Optical Link

Product Description

Trixon XFP series products is XFP form factor pluggable transceiver for duplex optical data communications. It's comply with XFP multi-source agreement (MSA: SFF-8077i), also be comply with 10-Gigabit Ethernet IEEE802.3ae and 10G Fiber Channel. The Digital diagnostics functions and standard transceiver serial ID information are available via a 2-wire serial interface according to XFP MSA, the transceiver is RoHS compliant and lead-free per Directive 2002/95/EC and 2005/747/EC.

Ordering information

Part No.	Data Rate	Laser	Fiber Type	Distance* ^{Note1}	Optical Interface	Bail Color	Temp.* ^{Note2}	DDMI
TXS-TGM3-85DCR	10.3G	850nm-VCSEL	MMF	300m	LC	Beige	ST	Y
TXS-TGM3-85DIR	10.3G	850nm-VCSEL	MMF	300m	LC	Beige	IT	Y
TXS-TG10-31DCR	10.3G	1310nm-DFB	SMF	10km	LC	Blue	ST	Y
TXS-TG10-31DIR	10.3G	1310nm-DFB	SMF	10km	LC	Blue	IT	Y
TXS-TG40-55DCR	10.3G	1550nm-EML	SMF	40km	LC	Red	ST	Y
TXS-TG40-55DIR	10.3G	1550nm-EML	SMF	40km	LC	Red	IT	Y
TXS-TG80-55DCR	10.3G	1550nm-EML	SMF	80km	LC	White	ST	Y
TXS-TG80-55DIR	10.3G	1550nm-EML	SMF	80km	LC	White	IT	Y

Note1: 300m with 50/125µm OM3 MMF, 10km/40km/80km with 9/125µm SMF

Note2: ST: -5 ~ +70 deg C IT: -40 ~ +85 deg C

Regulatory Compliance

Feature	Standard	Performance
Electrostatic Discharge (ESD) to the Electrical Pins	MIL-STD-883G Method 3015.7	HBM class 1, 1000volts and above, Contact discharge on Golden Finger.
Electrostatic Discharge to the enclosure	IEC-61000-4-2 GR-1089-CORE	Compliant with standards.
Electromagnetic Interference (EMI)	FCC Part 15 Class B EN55022:2006 VCCI Class B	Compliant with standards Noise frequency range: 30MHz to 18 GHz. System margins depend on customer host board and chassis design.
Immunity	IEC 61000-4-3	Compliant with standards.
Laser Eye Safety	FDA 21CFR 1040.10 and 1040.11 EN (IEC) 60825-1:2007 EN (IEC) 60825-2:2004+A1	CDRH compliant and Class I laser product.
Component Recognition	UL and CUL EN60950-1:2006	Compliant with standards.
RoHS6	2002/95/EC 4.1&4.2 2005/747/EC 5&7&13	Compliant with standards* ^{note3}

Note3:

In light of item 5 in RoHS exemption list of RoHS Directive 2002/95/EC, Item 5: Lead in glass of cathode ray tubes, electronic components and fluorescent tubes.

In light of item 13 in RoHS exemption list of RoHS Directive 2005/747/EC, Item 13: Lead and cadmium in optical and filter glass. The three exemptions are being concerned for Trixon transceivers, because Trixon transceivers use glass, which may contain Pb, for components such as lenses, windows, isolators, and other electronic components.

Absolute Maximum Ratings*^{Note4}

Parameter	Symbol	Min	Max	Unit
Storage Temperature	T _S	-40	+85	°C
Supply Voltage	V _{CC}	0	+4	V
Operating Humidity		5	95	%

Note4: Exceeding any one of these values may destroy the device permanently.

Recommended Operating Conditions

Parameter	Symbol	Min	Typical	Max	Unit	Notes
Operating Case Temperature	T_C	-5	-	70	°C	ST
		-40	-	85	°C	IT
Power Supply Voltage	VCC3	3.14	3.3	3.47	V	
	VCC5	4.75	5	5.25	V	Only 40km/80km products use
Power Dissipation	P	-	-	2	W	300m/10km ST/IT
		-	-	3.5	W	40km/80km ST/IT
Bit Rate		-	10.3125	-	Gbps	
I2C Clock Frequency	f_{cl}	-	-	100	kHz	

Performance Specifications – Electrical

Parameter	Symbol	Min	Typ.	Max	Unit	Notes
Transmitter						
TX CML Inputs Voltage (Differential)	V_{in}	150	-	800	mVpp	AC coupled inputs
Input Impedance (Differential)	Z_{in}	80	100	120	ohm	
Tx_DISABLE Input Voltage – High		2.0	-	Vcc+0.3	V	
Tx_DISABLE Input Voltage – Low		-0.3	-	0.8	V	
Indicator Output Logic - High		2	-	-	V	OC output, should be pull up with 4.7K – 10 K Ω on the host board
Indicator Output Logic - LOW		-	0.2	0.4	V	$I_{SINK_MAX} = 3mA$
Receiver						
CML Outputs Voltage (Differential)	V_{out}	100	-	800	mVpp	AC coupled outputs
Output Impedance (Differential)	Z_{out}	80	100	120	ohm	
Rx_LOS Output Voltage – High		2	-	-	V	OC output, should be pull up with 4.7K – 10 K Ω on the host board
Rx_LOS Output Voltage – Low		-	0.2	0.4	V	$I_{SINK_MAX} = 3mA$
MOD_DEF (0:2)	V_{OH}	2.5			V	
	V_{OL}	0		0.5	V	

Timing Specifications

Parameter	Symbol	Min	Typ.	Max	Unit
TX Disable Assert Time	T_{off}	-	-	10	us
TX Disable Negate Time	T_{on}	-	-	2	ms
Time to initialize	t_{init}	-	-	300	ms
/Interrupt assert delay	/Interrupt_on	-	-	200	ms
/Interrupt negate delay	/Interrupt_off	-	-	500	us
P_Down/RST assert delay	P_Down/RST_on	-	-	100	Us
Mod_NR assert delay	Mod_nr_on	-	-	1	ms

Mod_NR negate delay	Mod_nr_off	-	-	1	ms
P-Down reset time		10	-	-	us
RX_LOS Assert Time	T_los_on	-	-	100	us
RX_LOS De-Assert Time	T_los_off	-	-	100	us

Performance Specifications – Optical (850nm VCSEL and PIN, 300m)

Parameter	Symbol	Min	Typ.	Max	Unit
Transmitter					
Centre Wavelength	λ_c	840	850	860	nm
Spectral Width (RMS)	$\Delta\lambda$	-	-	0.65	nm
Average Output Power*note5	P _{out}	-7.3	-	-1	dBm
Extinction Ratio	ER	3	-	-	dB
Average Power of OFF Transmitter	P _{out-off}	-	-	-30	dBm
Transmitter Dispersion Penalty	TDP	-	-	3.9	dB
Optical Return Loss Tolerance	ORLT	-	-	12	dB
Output Optical Eye	Compliant with IEEE802.3ae-2005				
Receiver					
Centre Wavelength	λ_c	840	-	860	nm
Receiver Sensitivity*note6	SEN	-	-	-11.1	dBm
Receiver Overload	P _{max}	-1	-	-	dBm
LOS De-Assert	LOS _D	-	-	-10	dBm
LOS Assert	LOS _A	-20	-	-	dBm
LOS Hysteresis	LOS _H	0.5	-	4	dB

Note5: Output is coupled into a 50/125um OM3 MMF. The typical value is -2.5dBm.

Note6: Measured with a PRBS 2³¹-1 test pattern @10.3125Gbps, BER≤10⁻¹².

Performance Specifications – Optical (1310nm DFB and PIN, 10km)

Parameter	Symbol	Min	Typ.	Max	Unit
Transmitter					
Centre Wavelength	λ_c	1270	1310	1355	nm
Side Mode Suppression Ratio	SMSR	30	-	-	dB
Spectral Width (-20dB)	$\Delta\lambda$	-	-	1	nm
Average Output Power*note7	P _{out}	-8.2	-	0.5	dBm
Extinction Ratio	ER	3.5	-	-	dB
Average Power of OFF Transmitter	P _{out-off}	-	-	-30	dBm
Transmitter Dispersion Penalty	TDP	-	-	3.2	dB
Optical Return Loss Tolerance	ORLT	-	-	12	dB
Output Optical Eye	Compliant with IEEE802.3ae-2005				
Receiver					
Centre Wavelength	λ_c	1260	-	1610	nm
Receiver Sensitivity*note8	SEN	-	-	-14.4	dBm

Receiver Overload	P_{max}	0.5	-	-	dBm
LOS De-Assert	LOS_D	-	-	-14	dBm
LOS Assert	LOS_A	-25	-	-	dBm
LOS Hysteresis	LOS_H	0.5	-	4	dB

Note7: Output is coupled into a 9/125um SMF. The typical value is -2dBm.

Note8: Measured with a PRBS $2^{31}-1$ test pattern @10.3125Gbps, $BER \leq 10^{-12}$.

Performance Specifications – Optical (1550nm EML and PIN, 40km)

Parameter	Symbol	Min	Typ.	Max	Unit
Transmitter					
Centre Wavelength	λ_c	1530	-	1565	nm
Spectral Width (-20dB)	$\Delta\lambda$	-	-	0.3	nm
Side Mode Suppression Ratio	SMSR	30	-	-	dB
Average Output Power* ^{note9}	P_{out}	-4	-	4.7	dBm
Extinction Ratio	ER	3	-	-	dB
Average Power of OFF Transmitter	$P_{out-off}$	-	-	-30	dBm
Transmitter Dispersion Penalty	TDP	-	-	3.0	dB
Optical Return Loss Tolerance	ORLT	-	-	21	dB
Output Optical Eye	Compliant with IEEE802.3ae-2005				
Receiver					
Centre Wavelength	λ_c	1265	-	1610	nm
Receiver Sensitivity* ^{note10}	SEN	-	-	-15.8	dBm
Receiver Overload	P_{max}	-1	-	-	dBm
LOS De-Assert	LOS_D	-	-	-16.5	dBm
LOS Assert	LOS_A	-30	-	-	dBm
LOS Hysteresis	LOS_H	0.5	-	4	dB

Note9: Output is coupled into a 9/125um SMF. The typical value is +0.5dBm.

Note10: Measured with a PRBS $2^{31}-1$ test pattern @10.3125Gbps, $BER \leq 10^{-12}$.

Performance Specifications – Optical (1550nm EML and APD, 80km)

Parameter	Symbol	Min	Typ.	Max	Unit
Transmitter					
Centre Wavelength	λ_c	1530	-	1565	nm
Side Mode Suppression Ratio	SMSR	30	-	-	dB
Spectral Width (-20dB)	$\Delta\lambda$	-	-	0.3	nm
Average Output Power* ^{note11}	P_{out}	0	-	4	dBm
Extinction Ratio	ER	3.5	-	-	dB
Average Power of OFF Transmitter	$P_{out-off}$	-	-	-30	dBm
Transmitter Dispersion Penalty	TDP	-	-	3.0	dB
Optical Return Loss Tolerance	ORLT	-	-	21	dB

Output Optical Eye	Compliant with IEEE802.3ae-2005				
Receiver					
Centre Wavelength	λ_c	1260	-	1570	nm
Receiver Sensitivity* ^{note12}	SEN	-	-	-24	dBm
Receiver Overload	P_{max}	-7	-	-	dBm
LOS De-Assert	LOS _D	-	-	-22	dBm
LOS Assert	LOS _A	-36	-	-	dBm
LOS Hysteresis	LOS _H	0.5	-	4	dB

Note11: Output is coupled into a 9/125um SMF. The typical value is +2dBm.

Note12: Measured with a PRBS $2^{31}-1$ test pattern @10.3125Gbps, BER \leq 10⁻¹².

XFP Transceiver Electrical Pad Layout

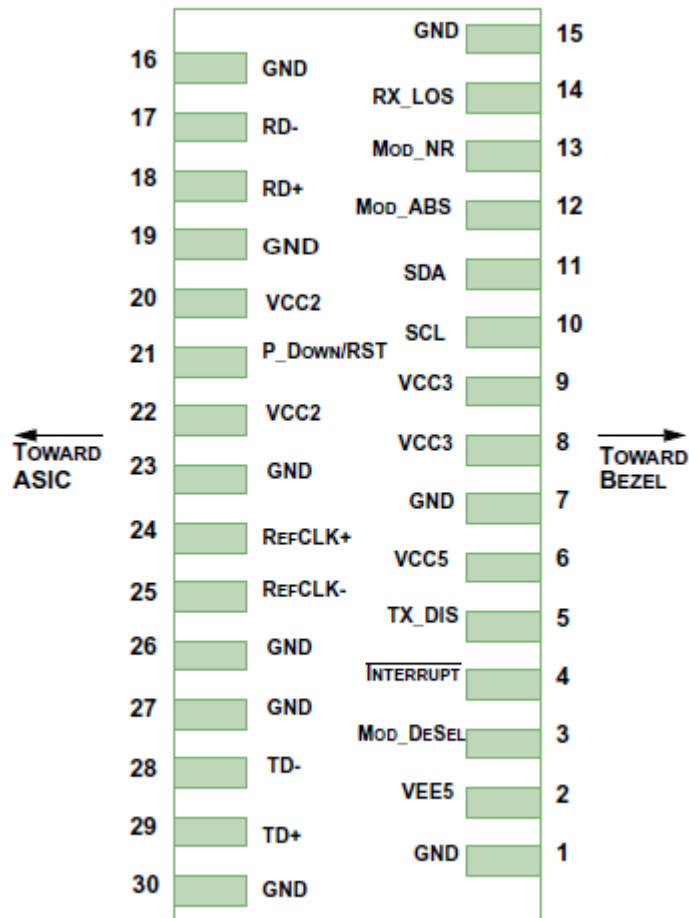

Host PCB XFP Pinout Top View

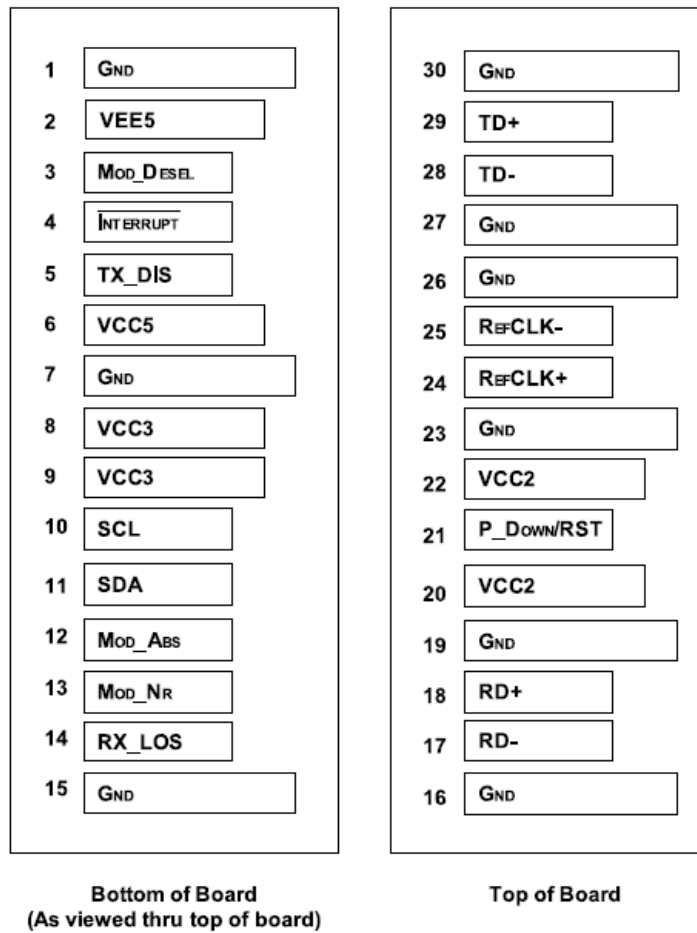

XFP Transceiver Electrical Pad Layout

Pin Function Definitions

Pin Num.	Logic	Name	Function	Notes
1		GND	Module Ground	13
2		VEE5	Optional -5.2V Power Supply	15
3	LVTTTL-I	Mod_DeSel	Module De-select; When held low allows module to respond to 2-wire serial interface	
4	LVTTTL-O	/Interrupt	Interrupt; Indicates presence of an important condition which can be read over the 2-wire serial interface	14
5	LVTTTL-I	TX_DIS	Transmitter Disable; Turns off transmitter laser output	
6		VCC5	+5V Power Supply	16
7		GND	Module Ground	13
8		VCC3	+3.3V Power Supply	
9		VCC3	+3.3V Power Supply	
10	LVTTTL-I/O	SCL	2-Wire Serial Interface Clock	14
11	LVTTTL-I/O	SDA	2-Wire Serial Interface Data Line	14
12	LVTTTL-O	Mod_ABS	Indicates Module is not present. Grounded in the Module	14
13	LVTTTL-O	Mod_NR	Module Not Ready; Indicating Module Operational Fault	14
14	LVTTTL-O	RX_LOS	Receiver Loss Of Signal Indicator	14
15		GND	Module Ground	13
16		GND	Module Ground	13
17	CML-O	RD-	Receiver Inverted Data Output	

18	CML-O	RD+	Receiver Non-Inverted Data Output	
19		GND	Module Ground	13
20		VCC2	+1.8V Power Supply	15
21	LVTTL-I	P_Down/RST	Power down; When high, requires the module to limit power consumption to 1.5W or below. 2-Wire serial interface must be functional in the low power mode. Reset; The falling edge initiates a complete reset of the module including the 2-wire serial interface, equivalent to a power cycle.	
22		VCC2	+1.8V Power Supply	15
23		GND	Module Ground	13
24	PECL-I	RefCLK+	Reference Clock Non-Inverted Input, AC coupled on the host board	
25	PECL-I	RefCLK-	Reference Clock Inverted Input, AC coupled on the host board	
26		GND	Module Ground	13
27		GND	Module Ground	13
28	CML-I	TD-	Transmitter Inverted Data Input	
29	CML-I	TD+	Transmitter Non-Inverted Data Input	
30		GND	Module Ground	13

Note13: Module ground pins Gnd are isolated from the module case and chassis ground within the module.

Note14: Shall be pulled up with 4.7K-10Kohms to a voltage between 3.15V and 3.45V on the host board.

Note15: Not use.

Note16: Only 40km/80km products use.

Digital Diagnostic Functions

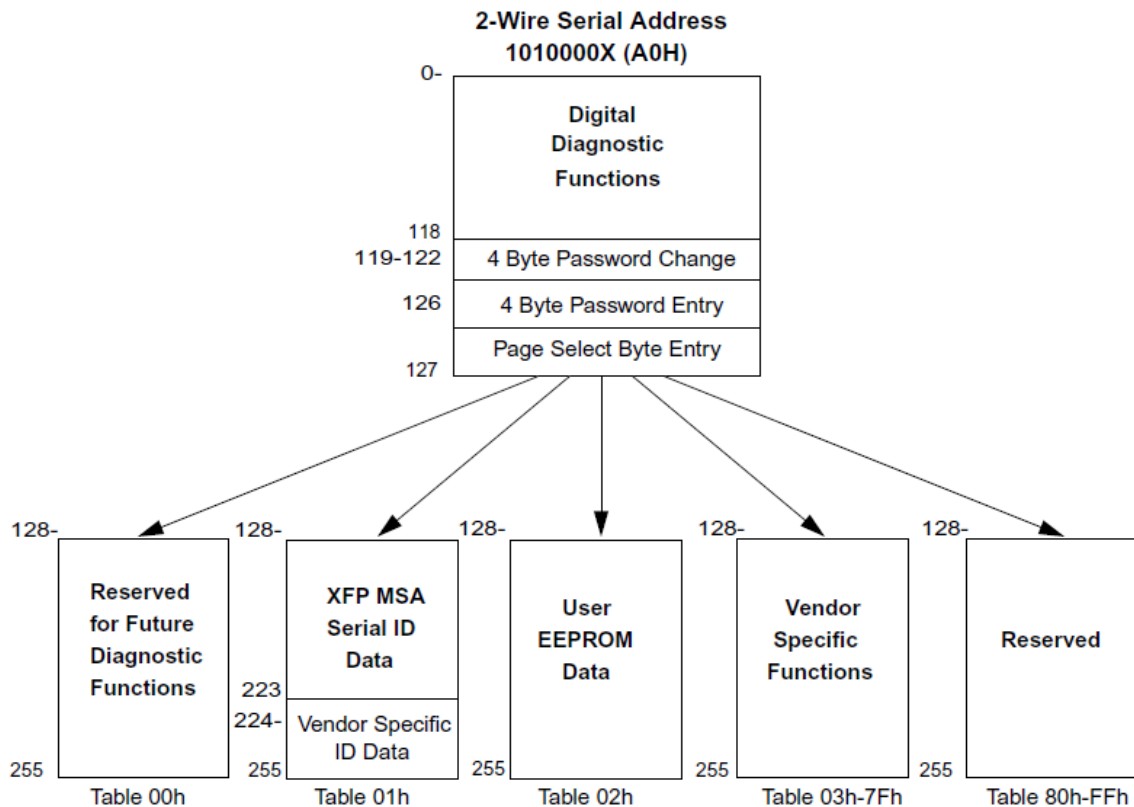

As defined by the XFP MSA, Trixon XFP series products provide digital diagnostic functions via a 2-wire serial interface, which allows real-time access to the following operating parameters:

- Transceiver temperature
- Laser bias current
- Transmitted optical power
- Received optical power
- Transceiver supply voltage

It also provides a sophisticated system of alarm and warning flags, which may be used to alert end-users when particular operating parameters are outside of a factory-set normal range.

The operating and diagnostics information is monitored and reported by a Digital Diagnostics Transceiver Controller (DDTC) inside the transceiver, which is accessed through the 2-wire serial interface. When the serial protocol is activated, the serial clock signal (SCL pin) is generated by the host. The positive edge clocks data into the XFP transceiver into those segments of its memory map that are not write-protected. The negative edge clocks data from the XFP transceiver. The serial data signal (SDA pin) is bi-directional for serial data transfer. The host uses SDA in conjunction with SCL to mark the start and end of serial protocol activation. The memories are organized as a series of 8-bit data words that can be addressed individually or sequentially. The 2-wire serial interface provides sequential or random access to the 8 bit parameters, addressed from 000h to the maximum address of the memory.

Digital Diagnostic Monitoring Specifications

Monitor accuracy				
Parameter	Min	Typ	Max	Units
Internally measured transceiver temperature	-		±3	°C
Internally measured transceiver supply voltage	-	-	±3%	V
Measured TX bias current	-	-	±10	%
Measured TX output power	-	-	±3	dB
Measured RX received average optical power	-	-	±3	dB

Dynamic range for operation*^{Note17}

Parameter		H-Alarm	H-Warning	L-Warning	H-Warning	Units
Internally measured transceiver temperature	ST	+85	+80	-5	-10	°C
	IT	+100	+95	-35	-40	
Internally measured transceiver supply voltage		3.63	3.47	3.13	2.97	V
Measured TX bias current	VCSEL Laser	12	11	2	1	mA
	DFB Laser	120	110	10	5	
	EML Laser	130	120	10	5	
Measured TX output power		Pout_MAX+1	Pout_MAX	Pout_MIN	Pout_MIN-1	dBm
Measured RX received average optical power		Overload+1	Overload	SEN	SEN-2	dBm

Note17: It is permissible to be adjusted according to the manufacturer's testing result.

Recommended Circuit

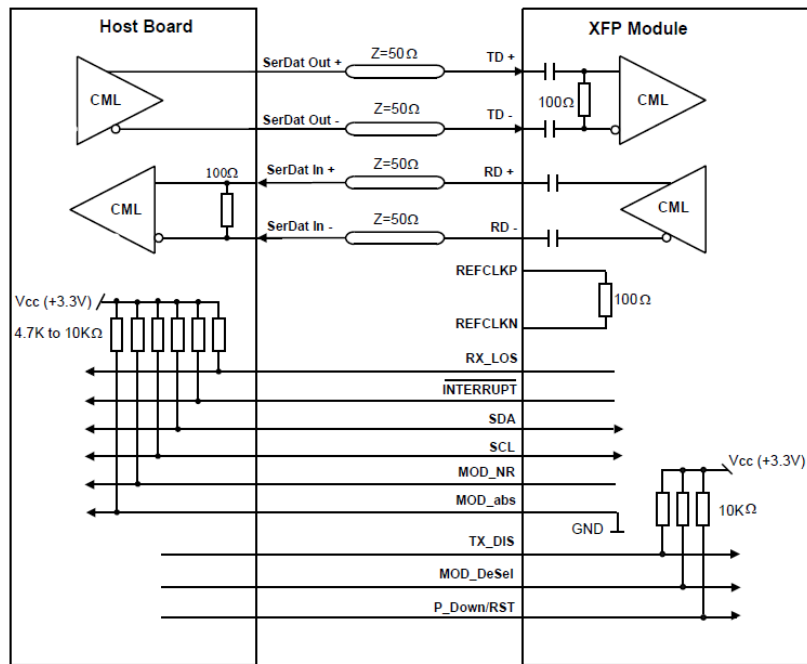

Recommended Host Board Power Supply Circuit

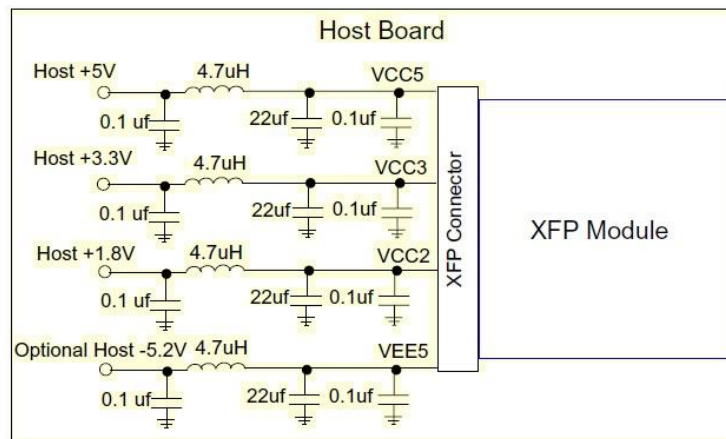

Mechanical Dimension

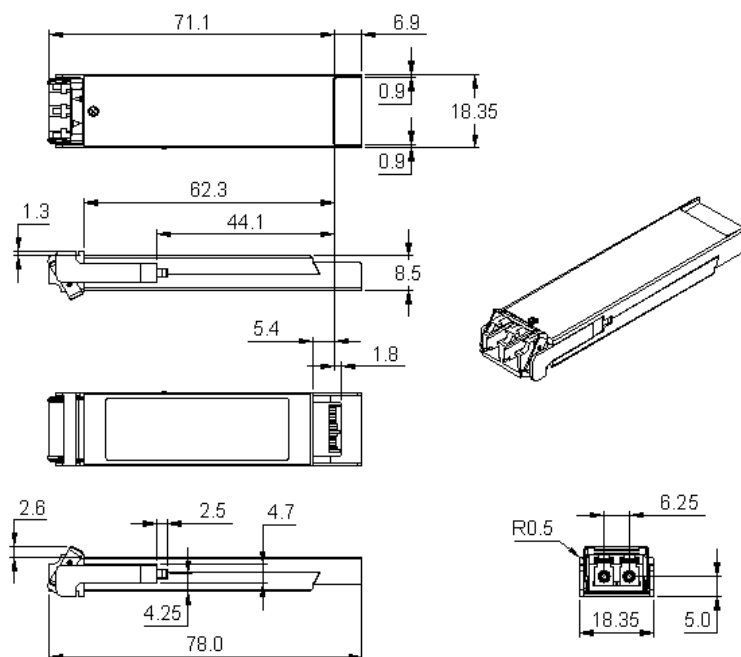

Eye Safety

These transceivers are Class 1 laser products. It complies with IEC-60825 and FDA 21 CFR 1040.10 and 1040.11. The transceiver must be operated within the specified temperature and voltage limits. The optical ports of the module shall be terminated with an optical connector or with a dust plug.

Obtaining Document

You can visit our website: <http://www.trixontech.com>

Or contact Trixon Inc. listed at the end of the documentation to get the latest document.

Notice

Trixon reserves the right to make changes to or discontinue any optical link product or service identified in this publication, without notice, in order to improve design and/or performance.

Applications that are described herein for any of the optical link products are for illustrative purposes only. Trixon makes no representation or warranty that such applications will be suitable for the specified use without further testing or modification.

Add: # 202, Section A, Building 1 No.209, Sanse Road, Jinjiang District Industry Park Chengdu
610063. Sichuan P.R. CHINA

Tel: (+86) 028-85925400/Fax: (+86) 028-85925445

E-mail: info@trixontech.com

<http://www.trixontech.com>

© Copyright Trixon 2014 All rights reserved.

