

TSP-EB66-43DCS

1.25G GEAPON OLT Transceiver

With Digital Diagnostic Function

Data Sheet



Features:

- Operating data rate up to 1.25 Gbps
- 1490nm DFB-LD Transmitter and 1310nm burst-mode APD-TIA Receiver
- Distance up to 20km
- Single 3.3V Power supply and TTL Logic Interface
- Digital burst RSSI function to monitor the input optical power level
- Single SC/UPC Connector Interface
- Hot Pluggable
- Compliant with MSA SFP Specification SFF-8472
- Compliant with IEEE 802.3ah
- Low EMI and Excellent ESD protection

Applications:

- FTTH
- Gigabit Ethernet Passive Optical Networks

Product Description

The GEAPON OLT transceiver is small form factor pluggable module for serial optical data communications such as IEEE 802.3ah 1000BASE-PX20+. It is with the SFP 20-pin connector to allow hot plug capability. This module is designed for single mode fiber and operates at a nominal wavelength of 1490 nm. The transmitter section uses a 1490nm DFB laser and is a class 1 laser compliant according to International Safety Standard IEC-60825.

Ordering information

Part No.	Data Rate	Laser	Fiber Type	Distance	Optical Interface	Temp.	DDMI
TSP-EB66-43DCS	1.25Gbps	DFB	Single-mode	20KM	SC/UPC	C	Yes
TSP-EB66-43NCS	1.25Gbps	DFB	Single-mode	20KM	SC/UPC	C	No

Regulatory Compliance

Feature	Standard	Performance
Electrostatic Discharge (ESD) to the Electrical Pins	MIL-STD-883G Method 3015.7	Class 1C (>1000 V)
Electrostatic Discharge to the enclosure	EN 55024:1998+A1+A2 IEC-61000-4-2 GR-1089-CORE	Compliant with standards
Electromagnetic Interference (EMI)	FCC Part 15 Class B EN55022:2006 CISPR 22B :2006 VCCI Class B	Compliant with standards Noise frequency range: 30 MHz to 6 GHz. Good system EMI design practice required to achieve Class B margins. System margins depend on customer host board and chassis design.
Immunity	EN 55024:1998+A1+A2 IEC 61000-4-3	Compliant with standards. 1kHz sine-wave, 80% AM, from 80 MHz to 1 GHz. No effect on transmitter/receiver performance is detectable between these limits.
RoHS6	2002/95/EC 4.1&4.2 2005/747/EC 5&7&13	Compliant with standards ^{*note1}

Note1: For update of the equipment and strict control of raw materials, Trixon has the ability to supply the customized products since Sep.2008, which meets the requirements of RoHS6 (Restrictions on use of certain Hazardous Substances) of European Union.

In light of item 5 in RoHS exemption list of RoHS Directive 2002/95/EC, Item 5: Lead in glass of cathode ray tubes, electronic components and fluorescent tubes.

In light of item 13 in RoHS exemption list of RoHS Directive 2005/747/EC, Item 13: Lead and cadmium in optical and filter glass. The three exemptions are being concerned for Trixon transceivers, because Trixon transceivers use glass, which may contain Pb, for components such as lenses, windows, isolators, and other electronic components.

Absolute Maximum Ratings^{*note2}

Parameter	Symbol	Min	Max	Unit
Storage Temperature	T _S	-40	85	°C
Supply Voltage	VCC	0	4	V
Operating Relative Humidity	OH	5	95	%

Note2: Exceeding any one of these values may destroy the device permanently.

Recommended Operating Conditions

Parameter	Symbol	Min	Typical	Max	Unit
Operating Case Temperature	T_C	-5		70	°C
Power Supply Voltage	VCC	3.13	3.3	3.47	V
Bit Rate			1.25		Gbps

Performance Specifications – Electrical

Parameter	Symbol	Min	Typ.	Max	Unit	Notes
Transmitter						
LVPECL Inputs Voltage (Differential)	V_{in}	200		1600	mVpp	AC coupled inputs
Input Impedance (Differential)	Z_{in}	90	100	110	ohm	
Tx_DISABLE Input Voltage – High		2.0		VCC	V	
Tx_DISABLE Input Voltage – Low		0		0.8	V	
Tx_FAULT Output Voltage – High		2.4		VCC	V	
Tx_FAULT Output Voltage – Low		0		0.4	V	
Receiver						
LVPECL Outputs Voltage (Differential)	V_{out}	400		1600	mVpp	DC coupled outputs
Output Impedance (Differential)	Z_{out}	90	100	110	ohm	
Rx_LOS Output Voltage – High		2.4		VCC	V	
Rx_LOS Output Voltage – Low		0		0.4	V	
RSSI Trigger-High		2.0		VCC	V	
RSSI Trigger-Low		0		0.8	V	

Timing Specifications

Parameter	Symbol	Min	Typ.	Max	Unit
TX Disable Assert Time	T_{off}			10	us
TX Disable Negate Time	T_{on}			1	ms
Time to initialize, include reset of TX_FAULT	T_{int}			300	ms
TX_FAULT from fault to assertion	T_{fault}			100	us
RX_LOS Assert Time			0.5		us
RX_LOS De-Assert Time			0.5		us
RSSI Trigger Width	T_w		300		ns
RSSI Trigger Delay	T_d			200	ns
Optical Signal During Time		600			ns
I2C Access Prohibited Time		100		500	us
I2C Read Time		150	200		us

Timing Parameter Definitions In Burst Mode Sequence

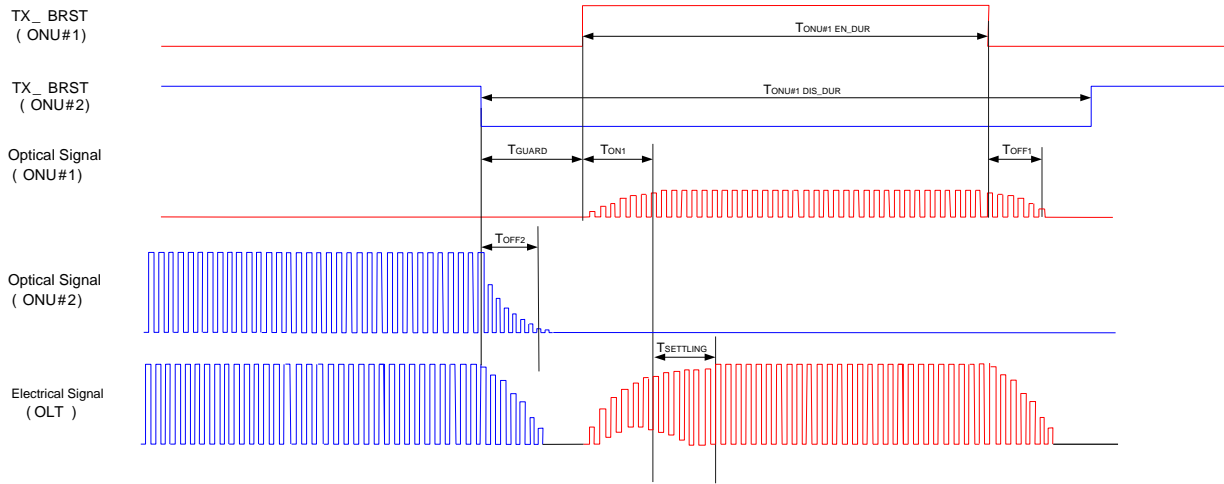

Burst Mode Receiver Dynamic Range In Gepon System

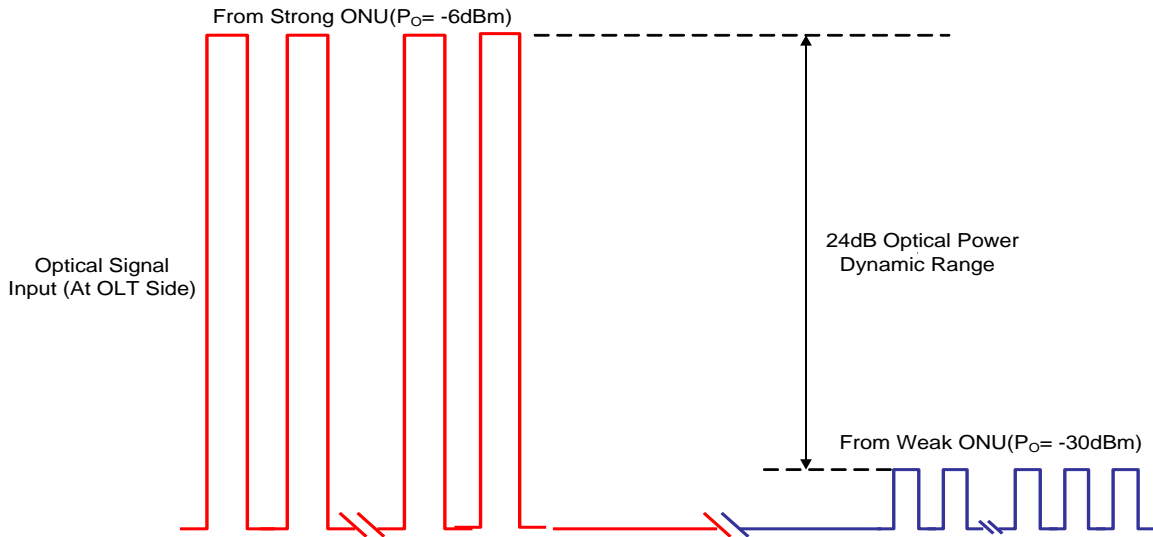

Fast RSSI Sequence

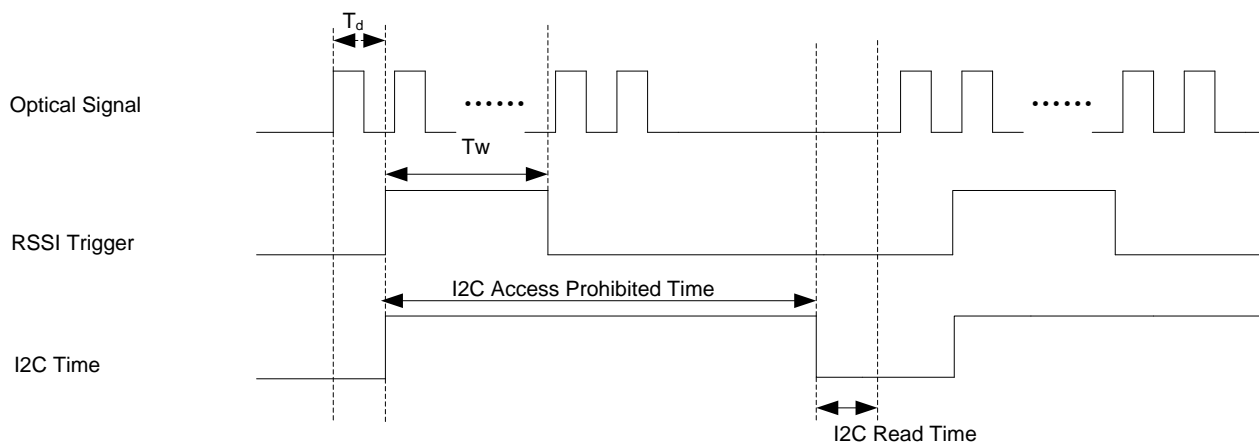

Performance Specifications – Optical (1490nm DFB and 1310nm APD, 20km)

Parameter	Symbol	Min	Typ.	Max	Unit
9µm Core Diameter SMF			20		Km
Data Rate			1.25		Gbps
Transmitter					
Centre Wavelength	λ_c	1480	1490	1500	nm
Spectral Width (-20dB)	$\Delta\lambda$			1	nm
Average Output Power	AOP	+2.5		+7	dBm
Extinction Ratio	ER	9			dB
Average Power of OFF Transmitter				-39	dBm
Transmitter Dispersion Penalty	TDP			2.3	dB
Total Jitter	TJ			0.43	UI(p-p)
Output Optical Eye	Compliant with IEEE Std 802.3ah™-2004				
Rise/Fall Time(20%-80%)				260	ps
Receiver					
Centre Wavelength		1260	1310	1360	nm
Sensitivity*note3	SEN			-30	dBm
Receiver Overload	SAT	-6			dBm
Optical Return Loss				-12	dB
LOS De-Assert				-31	dBm
LOS Assert		-45			dBm
LOS Hysteresis		0.5		4	dB

Note3: Minimum average optical power measured at the BER less than 1E-12, back to back. The measure pattern is PRBS 2⁷-1.

GEAPON OLT Transceiver Electrical Pad Layout

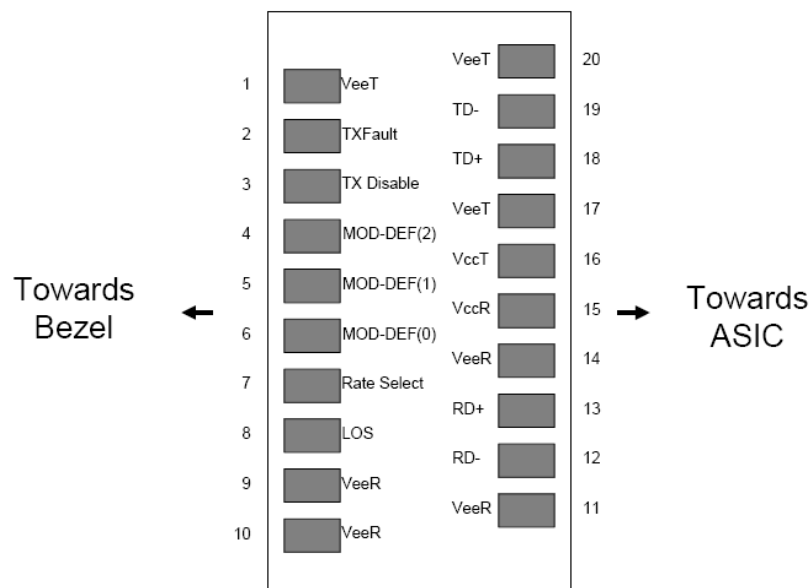

Diagram of Host Board Connector Block Pin Numbers and Names

Pin Function Definitions

Pin Num.	Name	Function	Plug Seq.	Notes
1	VeeT	Transmitter Ground	1	Note 7
2	TX Fault	Transmitter Fault Indication	3	Note 4
3	TX Disable	Transmitter Disable	3	Note 5, Module disables on high or open.
4	MOD_DEF2	Module Definition 2	3	2-wire Serial Interface Data Line.
5	MOD_DEF1	Module Definition 1	3	2-wire Serial Interface Clock.
6	MOD_DEF0	Module Definition 0	3	Connected to Ground in the transceiver
7	RSSI Trigger	RSSI Trigger for Transceiver A/D	3	High: enable RSSI A/D conversion
8	LOS	Loss of Signal	3	High: Loss Of Signal; Low: Signal Detect, Note6
9	VeeR	Receiver Ground	1	Note 7
10	VeeR	Receiver Ground	1	Note 7
11	VeeR	Receiver Ground	1	Note 7
12	RD-	Inv. Received Data Out	3	Note 8
13	RD+	Received Data Out	3	Note 8
14	VeeR	Receiver Ground	1	Note 7
15	VccR	Receiver Pow	2	3.3V ± 5%, Note 9
16	VccT	Transmitter Power	2	3.3V ± 5%, Note 9
17	VeeT	Transmitter Ground	1	Note 7
18	TD+	Transmit Data In	3	Note 10
19	TD-	Inv. Transmit Data In	3	Note 10
20	VeeT	Transmitter Ground	1	Note 7

Note4: TX Fault is an open collector/drain output, which should be pulled up with a 4.7K – 10K_Ω resistor on the host board. Pull up voltage between 2.0V and VccT/R+0.3V. When high, output indicates a laser fault of some kind. Low indicates normal operation. In the low state, the output will be pulled to < 0.8V.

Note5: TX disable is an input that is used to shut down the transmitter optical output. It is pulled up within the module with a 4.7K – 10 K_Ω resistor. Its states are: Low (0 – 0.8V): Transmitter on (>0.8, < 2.0V): Undefined. High (2.0 – 3.465V): Transmitter Disabled. Open: Transmitter Disabled.

Note6: LOS (Loss of Signal) is an open collector/drain output, which should be pulled up with a 4.7K –10K_Ω resistor. Pull up voltage between 2.0V and VccT/R+0.3V. When high, this output indicates the received optical power is below the worst-case receiver sensitivity (as defined by the standard in use). Low indicates normal operation. In the low state, the output will be pulled to < 0.8V.

Note7: The module signal ground contacts, VeeR and VeeT, should be isolated from the module case.

Note8: RD-/+ : These are the differential receiver outputs. They are DC-coupled.

Note9: VccR and VccT are the receiver and transmitter power supplies. They are defined as 3.3V ±5% at the SFP+ connector pin. Maximum supply current is 300mA. Inductors with DC resistance of less than 1 ohm should be used in order to maintain the required voltage at the SFP+ input pin with 3.3V supply voltage. When the recommended supply-filtering network is used, hot plugging of the SFP+ transceiver module will result in an inrush current of no more than 30mA greater than the steady state value. VccR and VccT may be internally connected within the transceiver module.

Note10: TD-/+ : These are the differential transmitter inputs. They are AC-coupled, differential lines with 100_Ω differential termination inside the module. The AC coupling is done inside the module and is thus not required on the host board

Digital Diagnostic Specifications

Parameter	Min	Typ	Max	Units	Ref
Monitor accuracy					
Internally measured transceiver temperature			±3	°C	
Internally measured transceiver supply voltage			±3%	mV	
Measured TX bias current			±10	%	
Measured TX output power			±3	dB	
Measured RX received average optical power			±2	dB	

Digital Diagnostic Functions:

- 1) GEAPON OLT transceiver supports the 2-wire serial communication protocol as defined in SFF-8472: in which defines a 256-byte memory map in EEPROM at 8 bit address 1010000X (A0h). The digital diagnostic monitoring interface be assigned with 8 bit address 1010001X (A2h). Additionally, SFP transceivers provide a unique digital diagnostic monitoring interface (DDMI), which allows real-time access to product operating parameters such as transceiver supply voltage, transceiver temperature, transmitted optical power, laser bias current and received optical power. It also defines alarm and warning threshold, which alerts end-users when particular operating parameters are outside of factory setting.
- 2) When the serial protocol is activated, the serial clock signal (SCL, Mod Def 1) is generated by the host. The positive edge clocks data into those segments of the EEPROM that are not write-protected. The negative edge clocks data from the SFP transceiver. The serial data signal (SDA, Mod Def 2) is bi-Directional for serial data transfer. The host uses SDA in conjunction with SCL to mark the start and end of serial protocol activation. The memories are organized as a series of 8-bit data words that can be addressed individually or sequentially.
- 3) Digital diagnostics for the TSP-EB66-43DCS are internally calibrated by default: Calibration and alarm/warning threshold data is written during device manufacturing.

PCB Layout and Bezel Recommendations

Notes:

1. Datum and basic dimensions established by customer
2. Pads and vias are chassis ground, 11 places
3. Thru holes, plating optional

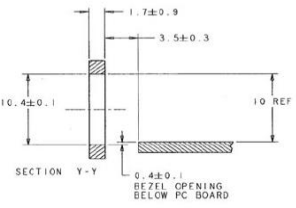
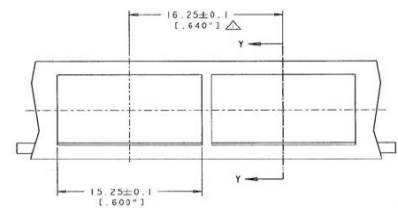
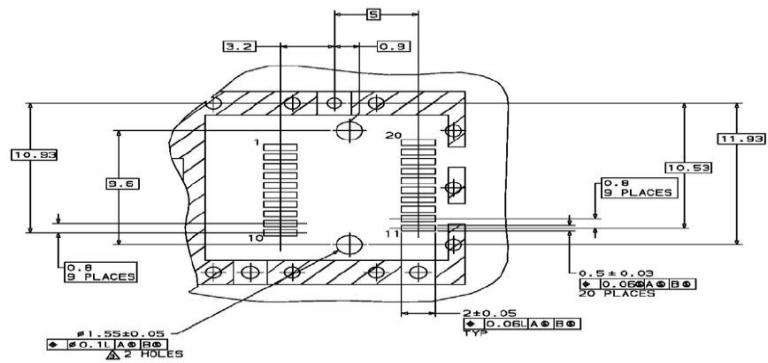
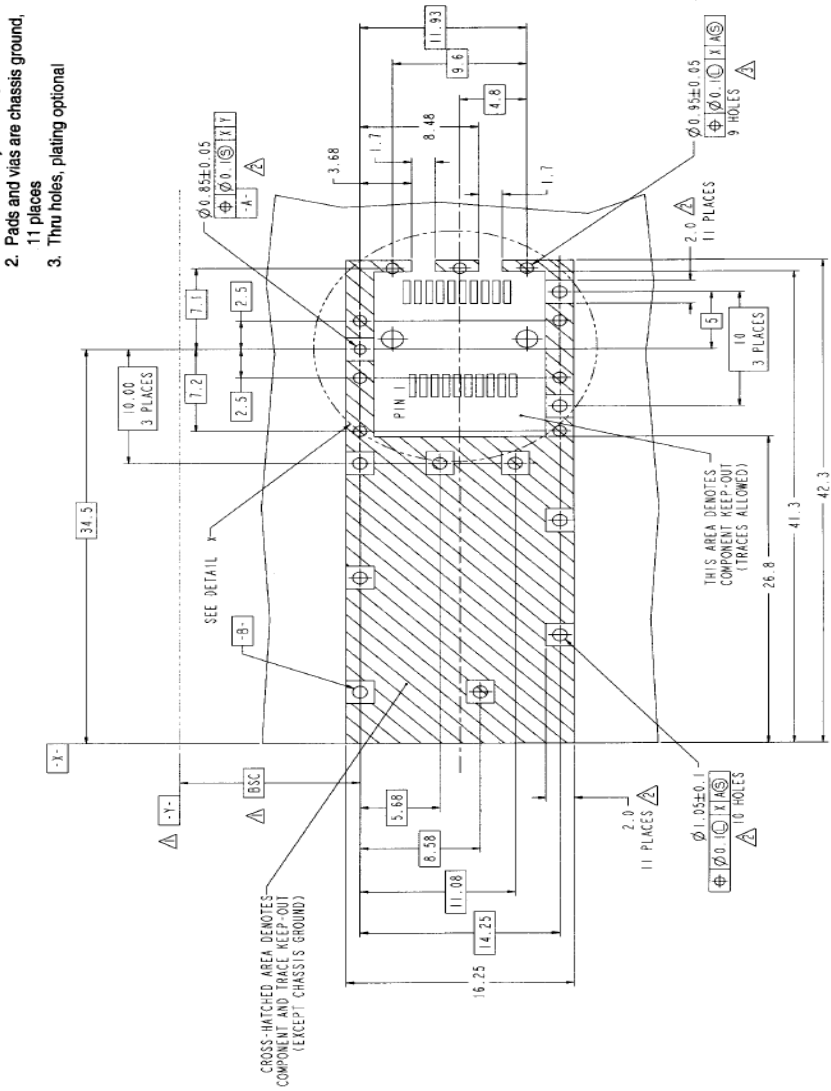

- NOTES:**
1. MINIMUM PITCH ILLUSTRATED, ENGLISH DIMENSIONS ARE FOR REFERENCE ONLY
 2. NOT RECOMMENDED FOR PCI EXPANSION CARD APPLICATIONS

Recommended Circuit

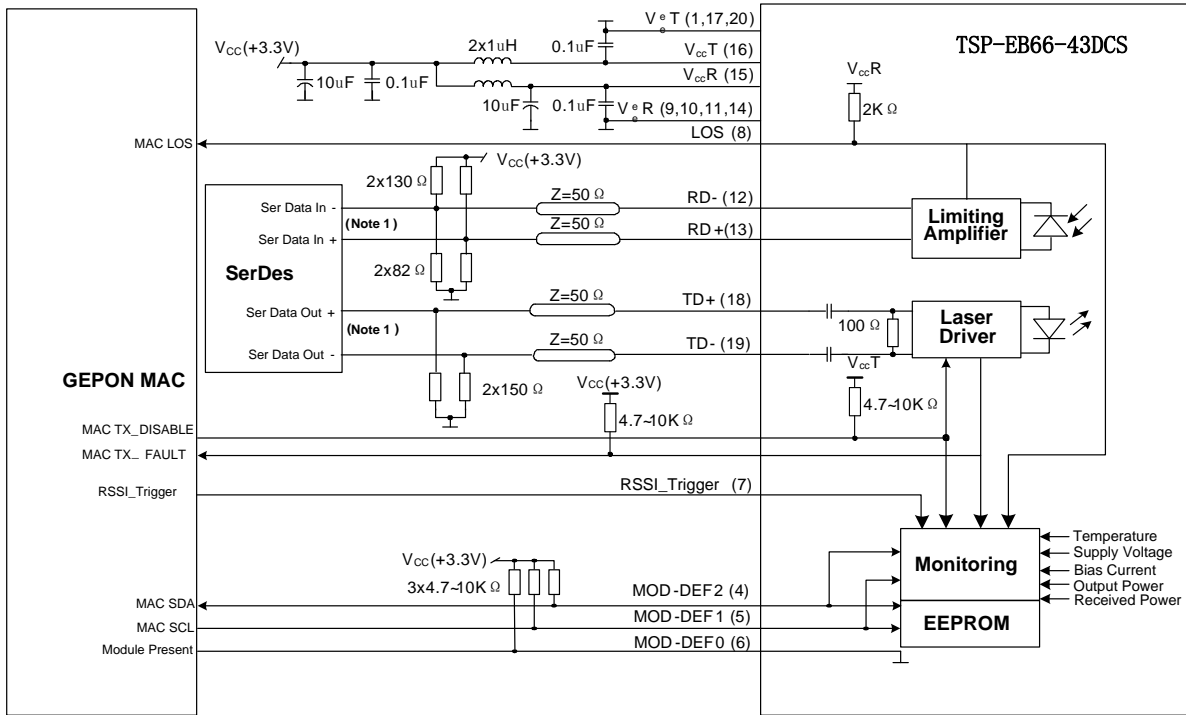

Mechanical Dimension

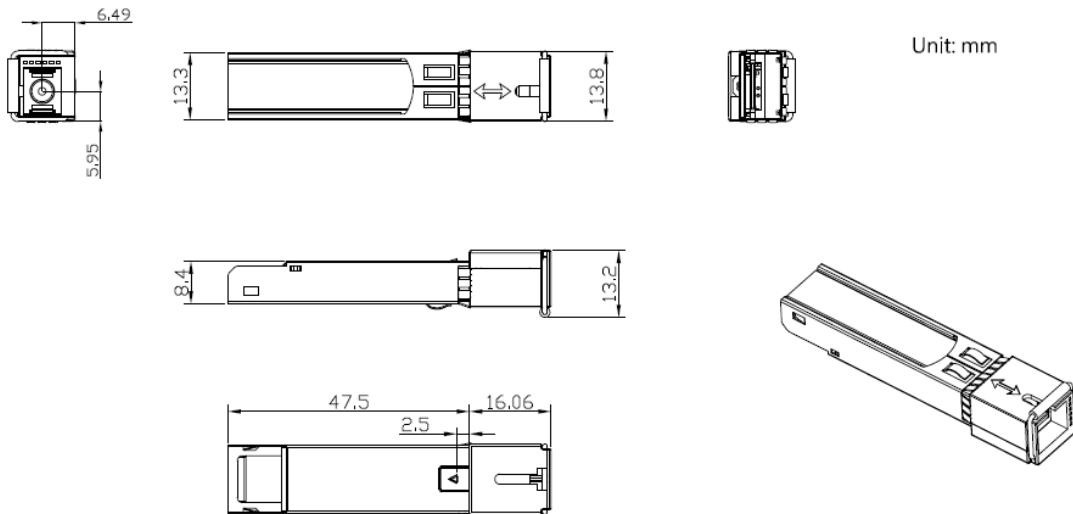

Eye Safety

This single-mode transceiver is a Class 1 laser product. It complies with IEC-60825 and FDA 21 CFR 1040.10 and 1040.11. The transceiver must be operated within the specified temperature and voltage limits. The optical ports of the module shall be terminated with an optical connector or with a dust plug.

Obtaining Document

You can visit our website: <http://www.trixontech.com>

Or contact Trixon Inc. listed at the end of the documentation to get the latest document.

Revision History

Revision	Initiator	Reviewed By	Approved By	Revision Description	Issue Date
V1.0	Tony Deng	Brian Tian	Jason	New Release	2014-5-13
V1.1	Tony Deng	Brian Tian	Jason	Update AOP range	2014-7-1

Notice

Trixon reserves the right to make changes to or discontinue any optical link product or service identified in this publication, without notice, in order to improve design and/or performance.

Applications that are described herein for any of the optical link products are for illustrative purposes only. Trixon makes no representation or warranty that such applications will be suitable for the specified use without further testing or modification.

Add: # 202,Section A,Building 1 No.209,Sanse Road,Jinjiang District Industry Park Chengdu
610063.Sichuan P.R. CHINA

Tel: (+86) 028-85925400/Fax: (+86) 028-85925445

E-mail: info@trixontech.com

<http://www.trixontech.com>

© Copyright Trixon 2014 All rights reserved

